Fastening of CETRIS[®] Cement Bonded Particleboards

Interior Anchoring	4.1
Exterior Anchoring Using Screws (Fasteners)	4.2

4.1 Interior Anchoring

CETRIS® boards can be fixed to the structures using screws, staples or nails. All types of fastening elements must be treated with an anti-corrosion agent; use of screws to fix plasterboard is not recommended. When using regular screws the screw holes should be pre-drilled to 1.2 multiple of the screw used. It is also recommended to prepare the countersinking for the sunken screw heads. For professional screwing it is recommended to use pneumatic or electrical screwdrivers with regulated revolutions.

The principles stated in this chapter (screwing to timber, sheet metal, stapling, nailing) also apply to exterior anchoring in cases where the board forms a base for a contact insulating system, or a composite roof system.

4.1.1 Screwing to Timber

For correct fixation of CETRIS® boards to constructions it is necessary to keep the maximum spacing of the load-bearing construction and the fixation elements. The best fastening element for fixation of CETRIS® boards is a self-tapping screw with double thread, hardened tip and sunken head with blades for countersinking. This type of screw may be supplied as an auxiliary material with CETRIS® label, diameter 4.2 mm, lengths 35, 45, 55 mm for connecting of two CETRIS® boards in the floating floor system or for board fixation to horizontal and vertical timber constructions (floors, partition walls, ceiling panels, etc.). For anchoring purposes the screw should penetrate to the wooden construction with at least 2/3 of its length. For fixation of floor boards, a screw of the length exceeding the board thickness by 20 mm will suffice.

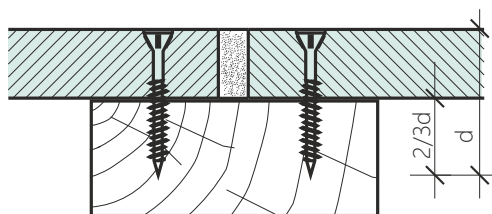

CETRIS self-tapping screw to timber

4.1.2 Screwing to Sheet Metal

For fixation of CETRIS® boards to sheet metal profiles there is the self-tapping screw, CETRIS® 4.2 × 25 mm (this screw is threaded up to the head), or screws 4.2 × 35, 45, 55 mm (thread up to about 2/3 of the shank length). The most often used load-bearing constructions include zinc-coated CW and UW profiles. Horizontal UW profiles are anchored via sound absorbing inserts to the ceiling (floor) construction. Vertical CW profiles are inserted in the UW profiles, about 15 mm short of the room height. The CETRIS® board for wall cladding is only fixed to the vertical profiles (stands – CW). When anchoring to sheet metal profiles the screw should protrude by at least 10 mm through the thickness of the board. It is recommended to pre-drill the CETRIS® board. At the contact point – of the vertical joint and the vertical CW profile – first anchor the CETRIS® board closer to the stand of the CW profile. In the case of the opposite procedure (anchoring to the soft part of the CW profile) there is the risk of deformation of the profile and subsequently the cladding!

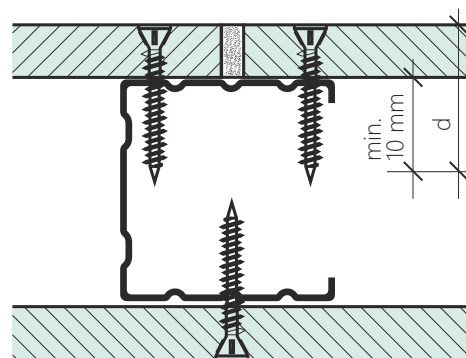

CETRIS self-tapping screw to sheet metal

A) Specification of resistance to the screw pulling out perpendicularly to the board plane:

Test method: ČSN EN 320
 Screw type: CETRIS 4,2 x 35 mm
 (pre-drilled hole in the board with a diameter of 3.5 mm)

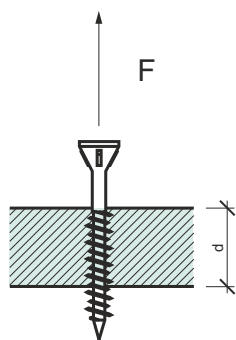

Board thickness d	Resistance
8 mm	597 N
10 mm	788 N
12 mm	1305 N

Interior wall – no fire resistance requirement (or exterior cladding under contact thermal insulation systems)

Board thickness (mm)	Screw spacing a (mm)	Beam spacing b (mm)	Distance of screws from vertical edge c_1 (mm)	Distance of screws from horizontal edge c_2 (mm)
8	< 200	< 420	> 20 < 50	> 50 < 100
10	< 250	< 500		
12, 14	< 250	< 625		
16, 18, 20	< 300	< 670		
22, 24, 26, 28, 30	< 350			
32, 34, 36, 38, 40	< 400			

Interior ceiling - no fire resistance requirement (or exterior cladding under contact thermal insulation systems)

Board thickness (mm)	Screw spacing a (mm)	Beam spacing b (mm)	Distance of screws from vertical edge c_1 (mm)	Distance of screws from horizontal edge c_2 (mm)
8	< 200	< 420	> 20 < 50	> 50 < 100
10	< 250	< 500		
12	< 300	< 625		

Interior ceiling – with fire resistance requirement (or exterior cladding under thermal insulation systems)

Board thickness (mm)	Screw spacing a (mm)	Beam spacing b (mm)	Distance of screws from vertical edge c_1 (mm)	Distance of screws from horizontal edge c_2 (mm)
12	< 200	< 420	> 20 < 50	> 50 < 100

B) Specification of resistance to the screw pulling out parallel to the board plane:

Test method: ČSN EN 320
 Screw type: CETRIS 4,2 x 35 mm
 (pre-drilled hole in the board with a diameter of 3.5 mm)

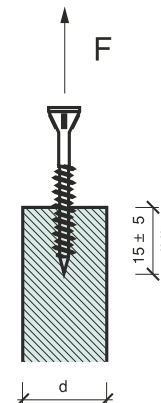

Board thickness d	Resistance
22 mm	1039 N

Note: informative values.

Interior wall – with fire resistance requirement (or exterior cladding under thermal insulation systems)

Board thickness (mm)	Screw spacing a (mm)	Beam spacing b (mm)	Distance of screws from vertical edge c_1 (mm)	Distance of screws from horizontal edge c_2 (mm)
10, 12, 14, 16, 18	< 200	< 625	> 20 < 50	> 50 < 100

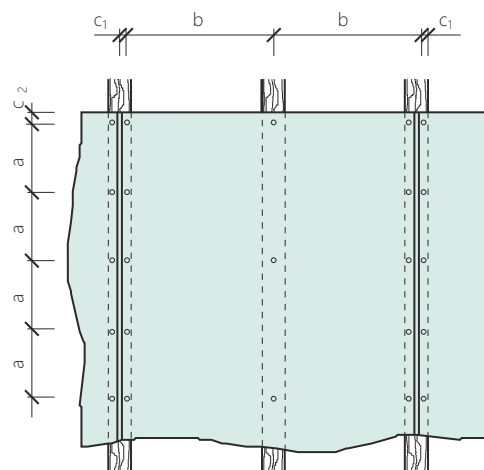

Flooring constructions – for details, see Chapters 6.6 and 6.7

Board thickness (mm)	Screw spacing a (mm)	Beam spacing b (mm)	Distance of screws from vertical edge c_1 (mm)	Distance of screws from horizontal edge c_2 (mm)
12 (ZOCET, POLYCET floating floors)	Upper layer pre-drilled, max. 300 mm		>20 <50	50
16,18,20,22,24 CETRIS PD (PDB)	< 300	Pursuant to load tables		
26,28,30,32,34, 36,38 CETRIS PD (PDB)	< 400			

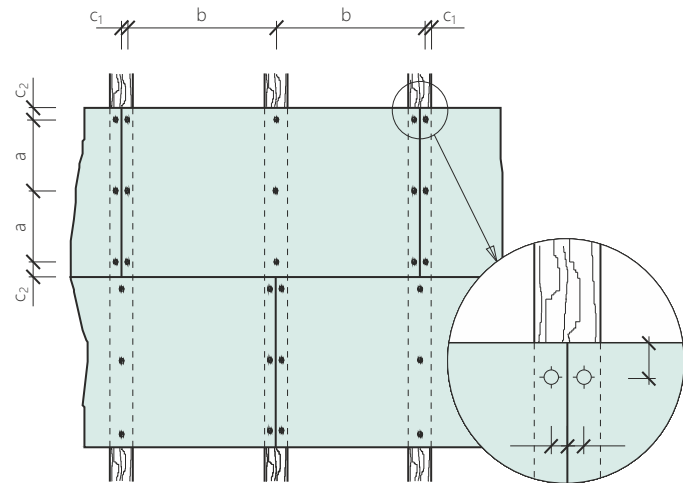

The Quik Drive® system with automatic screw feed is an efficient way to economically assemble the screw. With a large variety of modular system components and screws, there is a suitable Quik Drive® kit for every application - from drywall installation to sheet metal wood floor construction. Ideal for ergonomic and time-saving screw installation on walls, floors and ceilings. The Quik Drive® system is easy to use and can be used with an adapter for standard screwdrivers. The patented screw strips are designed to prevent failures.



Recommended screws for anchoring CETRIS® cement-bonded particleboards:

- Screw CBSDQ41E 4,1x41 mm /square-point extender/ - suitable for anchoring CETRIS® boards to steel construction 0.75 mm (trapezoidal sheet metal, wing breakage has also occurred), 3 mm, 4 mm. Screw length suitable for CETRIS® boards up to 24 mm thick.
- Screw FHSDE64E 5,5x64 mm /square-point extender/ - suitable for anchoring CETRIS® boards to steel structure thickness 3 mm, 4 mm, 6 mm. Screw length suitable for CETRIS® boards up to 40 mm thick.
- Screw TBG645e 6,1x45 mm /square-point extender/ - suitable for anchoring CETRIS® boards to steel structure 6 mm, 10 mm thick. Screw length suitable for CETRIS® boards up to 28 mm thick.



4.1.3 Nailing

Nailing may be used to anchor CETRIS® cement bonded particleboards of thickness 8 - 22 mm. Recommended board nailing principles:

- nail diameter $d_n = 2,1-2,5$ mm.
- minimum nail length = board thickness + 30 mm (min)
- nails must not be embedded lower than 2 mm.

- nailer types Duo Fast CNP 50.1, CNP 65.1, Haubold RNC 50M, RNC 65 S/WII, recommended working pressure 6 - 8 bar (max. 8 bar).
- minimum nail spacing in boards on a wooden base, the minimum nail spacing from the non-stressed edge of the board is 5. d_n , the minimum nail spacing from the stressed edge of the board is 7. d_n .
- the mutual spacing of the nails in the boards is minimum 20. d_n , maximum 75 mm (edge support), 150 mm (inner reinforcements).



4.1.4 Stapling

Pneumatic staplers are used for fixation of the cement bonded particleboards (static load-bearing and non-load-bearing) to a wooden base (beam, column, KV prism, and the like). Various models are available according to the type and thickness of the board. The models differ in the type of staple used (wire diameter) and size of the body for higher impact force.

Staple types KG 700 CNK geh / DIN 1052 /, wire diameter 1.53 mm
 KG 700 CDNK geh, for joint / board on board /
 KG 745 CNK geh for board of max. th. 10 mm to wood.
 KG 722 CDNK geh for joining of the board to a board of thickness 12x12 mm.
 KG 718 CDNK geh for joining of the board to a board of thickness 10x12 mm.
 Recommended staplers: PN 755 XI/Kontakt, PN 755 XI/Automat

- staple length up to 55 mm
- the Automat version has a rate of up to 300 staples /min

HD 7900 CNK geh /DIN 1052/, wire diameter 1.83 mm
 SD 9100 CNK geh /DIN 1052/, wire diameter 2.00 mm
 Stapler PN 9180 XII/ Kontakt

- staple length up to 75(80) mm
- model XII with high impact force

Recommended board stapling principles

- minimum staple distance from board edge 20 mm
- minimum staple spacing 30 mm (36 mm for the HD7900 staples and SD9100), max. 75 mm (around the perimeter), max. 150 mm inside the board area
- staples obliquely to the board edge, at least under an angle of 30°

Recommended staple length (HD 7900 CNK geh, SD 9100 CNK geh)

Board thickness (mm)	12	14	16	18	20	22
Staple length (mm)	45	50	60	70	70	70

4.2 Exterior Anchoring - Screws (Fasteners)

Façade cladding with visible horizontal and vertical joints – VARIO system – for details see Chapter 7.1.3.1.

CETRIS® boards are fixed in the VARIO system (façades, skirting lining, roof overhangs, suspended ceilings...) with stainless steel or galvanized screws with semi-circular or hexagonal heads and compressive water-tight washers. These washers are treated on the bottom side with vulcanized elastomer EPDM for water-tight and flexible material connection. The screw type also depends on the base type – the load-bearing grid applied. It is also possible to use rivets to fix the boards to galvanized (aluminium) constructions. (See Chapter 7.1.6.2)

Pre-drilling of the boards (applies to a screw / rivet diameter of up to 5 mm). CETRIS® boards must be pre-drilled:

- Diameter 8 mm for board lengths up to 1,600 mm
- Diameter 10 mm for board lengths over 1,600 mm

For position stabilisation at least one fixed point (with the diameter of 5 mm) is needed. Dilations between boards 5 – 10 mm.

VARIO anchoring table

Board thickness (mm)	Screw spacing a (mm)	Beam spacing b (mm)	Distance of screws from vertical edge c_1 (mm)			Distance of screws from horizontal edge c_2 (mm)
			Timber	Zinc	Aluminium	
8	< 400	< 420	>25 < 50	>30 < 50 >50 < 70 *	>50 < 70	>70 < 100
10	< 500	< 500				
12	< 500	< 625				
14	< 550	< 625				
16	< 550	< 700				

* Applies to the installation of the CETRIS® boards with horizontal dimension > 1,875 mm

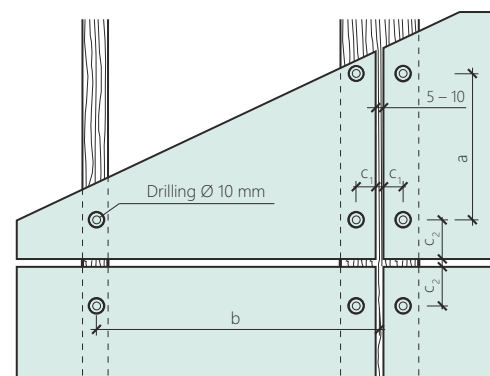

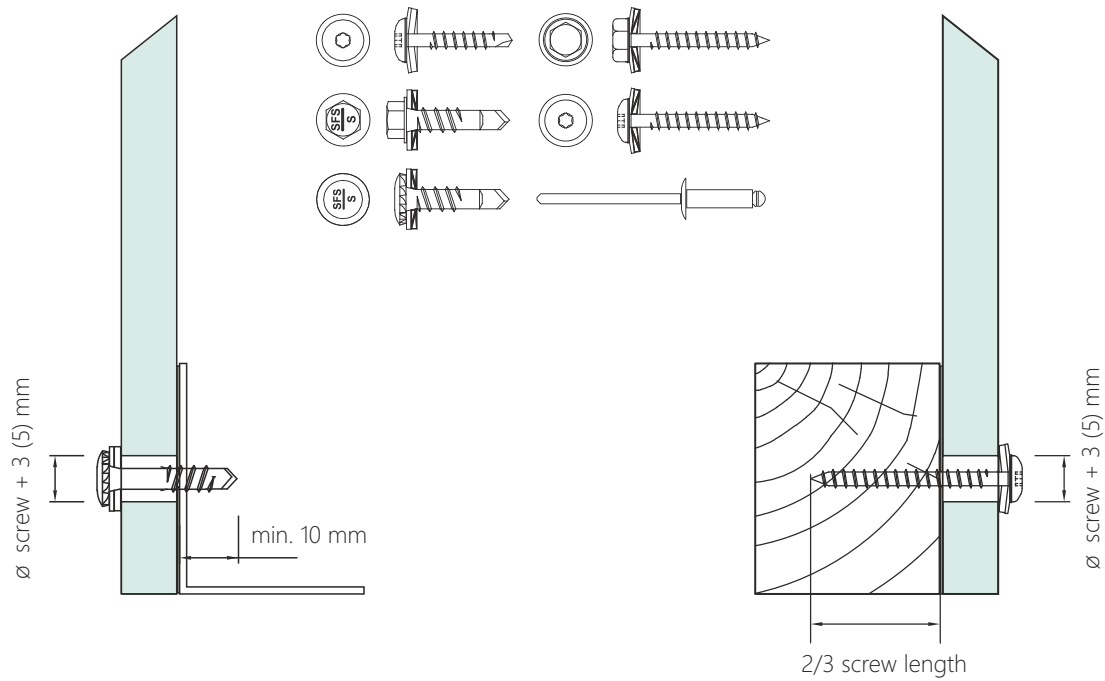

Façade cladding with overlapped joints – PLANK system

– for details see Chapter 7.1.3.2.

CETRIS® boards in the PLANK system (overlapped) are fixed with galvanized screws or stainless steel screws with sunken heads.

Pre-drilling of the boards (applies to a screw diameter of up to 5 mm):

- outer – diameter of 8 mm
- inner – 1.2 times of the screw diameter

Note: The recommended maximum length of CETRIS® board for PLANK system equals triple the span of the auxiliary vertical profiles (laths) – i.e. for board thickness 10 mm is max. 1,500 and for board thickness 12 mm is 1,875 mm.

PLANK anchoring table

Board thickness (mm)	Screw spacing a (mm)	Support span b (mm)	Screw distance from vertical edge c_1 (mm)	Screw distance from horizontal edge c_2 (mm)	Maximum length of board (mm)
			Timber / Zinc coat / Aluminium		
8	< 400	< 420	> 35 < 50	min. 40	1260
10	< 400	< 500			1500
12	< 350	< 625			1875
14	< 400	< 625			1875
16	< 400	< 700			2100

* Applies to the installation of the CETRIS® boards with horizontal dimension > 1,875 mm

