

Ceilings and plinths



Roofs



Balconies



Fire protection



Walls



Permanent shuttering



Road constructions



Facades



Floors



Hobby



**CETRIS<sup>®</sup>**

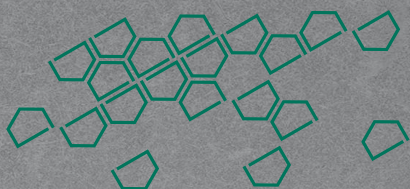

<b>1 Introduction</b>	
1.1 Introduction of Company	6
1.2 Quality Policy of CETRIS® Division	7
1.3 References	8
<b>2 Manufacturing Programme</b>	
2.1 Manufacturing of CETRIS® cement bonded particleboard	12
2.2 Merits of CETRIS® cement bonded particleboards	13
2.3 Composition of CETRIS® cement bonded particleboards	14
2.4 Types of CETRIS® cement bonded particleboards	14
Boards without surface finish	
2.4.1 CETRIS® BASIC	14
2.4.2 CETRIS® PD	15
2.4.3 CETRIS® PDB	15
2.4.4 CETRIS® PDI	16
2.4.5 CETRIS® PROFIL	16
2.4.6 CETRIS® AKUSTIC	17
Boards with surface finish	
2.4.7 CETRIS® PLUS	17
2.4.8 CETRIS® PROFIL PLUS	18
2.4.9 CETRIS® FINISH	18
2.4.10 CETRIS® PROFIL FINISH	19
2.4.11 CETRIS® LASUR	19
2.4.12 CETRIS® AKUSTIC FINISH	20
2.4.13 CETRIS® DEKOR	20
2.5 Packaging, Storage and Handling	21
2.6 Parameters of Shipped Boards	22
2.6.1 Size Tolerances	22
2.6.2 Appearance	22
<b>3 Basic Properties of CETRIS® Cement Bonded Particleboard</b>	
3.1 Basic Properties	26
3.2 Linear Expansion	26
3.3 Load Tables	27
3.4 Thermal Properties	30
3.5 Sound Insulation Properties	30
3.6 Vapour Permeability	33
3.7 Fire Protection Properties	34
3.8 Board Resistance against Arc Discharge of High Voltage and Low Intensity	34
<b>4 Processing of CETRIS® Cement Bonded Particleboard</b>	
4.1 Cutting	36
4.2 Drilling	36
4.3 Milling	36
4.4 Sanding	36
<b>5 Fastening of CETRIS® Cement Bonded Particleboard</b>	
5.1.1 Interior Anchoring	38
5.1.2 Exterior Anchoring	39
5.1.3 Support Span, Screw (Bolt) Spacing	39
<b>6 Surface Finishes of CETRIS® Cement Bonded Particleboard</b>	
6.1 Joint filling with permanently elastic filler	42
6.3 Interior Plasters	45
<b>7 CETRIS® Floor Systems</b>	
7.1 Types of CETRIS® Flooring Systems	48
7.2 Applications of CETRIS® Floor Boards	49
7.3 Types of CETRIS® Floor Boards	50
7.3.1 CETRIS® PD Floor Boards	50
7.3.2 CETRIS® PDB Floor Boards	50
7.3.3 CETRIS® Floor Boards for Floating (Two-Layer) Floors	51
7.3.4 CETRIS® PDI two-ply panel for dry floor technology	51
7.4 General Principles of Assembly of CETRIS® Floors	52
7.4.1 Fixing of CETRIS® Floor Boards	52
7.4.2 Dilation Joints and CETRIS® Floor Board Laying	52
7.5 Floating Floors of CETRIS® Boards	54
7.5.1 IZOCET Floating Floor	54
7.5.2 POLYCET Floating Floors	61
7.5.3 Floor panel CETRIS® PDI	75
7.6 CETRIS® PD and CETRIS® PDB Floors Systems on Load-Bearing Flat Base	79
7.6.1 Load-Bearing Base, Requirements, Laying	80
7.7 CETRIS® PD and CETRIS® PDB Floor Systems on Joists	81
7.7.1 Description of Construction	81
7.7.2 Load Tables	81
7.7.3 Laying of CETRIS® PD and CETRIS® PDB Floors	86
7.8 Two-Layer CETRIS® Floors on Beams	87
7.8.1 Description of Construction	87
7.8.2 Load Tables	87
7.8.3 Laying of CETRIS® Boards	88
7.9 Floor covering	89
7.9.1 Preparation of Surface of CETRIS® Floor Boards for Laying of Floor Finish	89
7.9.2 PVC, Carpets	90
7.9.3 Wooden Parquet	90
7.9.4 Ceramic Pavement	91
7.9.5 Ceramic Pavement with Hydro Insulating Foil	91
7.9.6 System Solution under Ceramic Pavement	92
7.9.7 Self-Levelling Cast Floor, Electrostatically Conductive	92
7.9.8 Comfort Cast Decorative Elastic Floor	93
7.10 Floor Heating	93
7.10.1 Floor Heating under CETRIS® boards	93
7.10.2 Floor Heating over CETRIS® boards	93
<b>8 CETRIS® Façade Systems</b>	
8.1 Application Options of CETRIS® Vented Façades	96
8.1.1 Advantages of CETRIS® Vented Façades	96
8.1.2 Categorization of CETRIS® Façade Systems	97
8.2 Types of CETRIS® Boards for Façade Systems	98
8.2.1 CETRIS® BASIC and CETRIS® PROFIL	98
8.2.2 CETRIS® PLUS and CETRIS® PROFIL PLUS	98
8.2.3 CETRIS® FINISH	98
8.2.4 CETRIS® PROFIL FINISH	98
8.2.5 CETRIS® LASUR	98
8.2.6 CETRIS® DEKOR	98
8.3 CETRIS® VARIO Façade System	99
8.4 CETRIS® PLANK Façade System	100
8.5 Processing of CETRIS® Façade Boards	101
8.6 Packaging and Storage of CETRIS® Façade Boards	101
8.7 Composition of CETRIS® Façade System	101
8.7.1 Base Construction	101
8.7.2 Heat Insulation	101
8.7.3 Air Gap	101
8.7.4 Wind Tight Safety Hydro Insulation	102
8.7.5 Wooden Load-Bearing Grid	102
8.7.6 Aluminium Load Bearing Grid – Profiles STYL 2000	102
8.7.7 Auxiliary Materials	104
8.8 Technological Procedure of Assembly of CETRIS® Façade System	106
8.8.1 Assembly of Wooden Load-Bearing Façade Construction	108
8.8.2 Assembly of Aluminium or Zinc-Coated Load-Bearing Construction	108
8.8.3 Assembly of DEKMETAL Load-Bearing Construction	110
8.8.4 ETANCO Load-Bearing Construction	112
8.8.8 Detail Implementation of CETRIS® Façade Systems	115

8.9 Railing, Terrace, Loggia and Balcony panels of CETRIS® Boards . . .135
8.9.1 Recommended and Tested Variants of Solutions of Railing panels of CETRIS® Board . . . . .135
8.10 Roof Overlap Underside Covering . . . . .137
8.11 Cladding of Bottom Structure (Basement) . . . . .138
<b>9 Application of CETRIS® Boards in Fire Protection pursuant to EN Standards</b>
9.1 Fire Protection of Building Constructions . . . . .140
9.1.1 Requirements of Fire Safety of Building Constructions . . .140
9.1.2 Fire-Related Properties of Building Materials – Flame Spread, Classification Based on National Standards 140
9.1.3 Classification of Building Products in Euro Classes depending on the reaction to fire . . . . .140
9.1.4 Fire Resistance of Building Constructions . . . . .142
9.2 Vertical Wall Constructions . . . . .143
9.2.1 Applicability Range . . . . .143
9.2.2 Fire Partitions, Shaft Wall on Steel Framework . . . . .148
9.2.3 Advanced Walls and Direct Fire Cladding of Walls . . . . .153
9.2.4 Fire Walls with Wooden Supporting Structure Clad by Cement Bonded Particle Board CETRIS®. . . . .156
9.3 Horizontal Constructions – Ceiling Panels . . . . .158
9.3.1 Applicability Range . . . . .158
9.3.2 Separate Fire Ceiling Panel . . . . .161
9.3.3 Fire Ceiling Panels under Ceiling (Roof) Construction . . . .169
9.4 Horizontal Constructions – Ceilings and Floors . . . . .170
9.4.1 Introduction . . . . .170
9.4.2 General Principles of Assembly . . . . .171
9.5 Steel Construction Cladding with CETRIS® Cement Bonded Particleboards. . . . .172
9.5.1 Introduction . . . . .172
9.5.2 Calculation of Ap/V . . . . .172
9.5.3 Methods of Cladding (directly, or on auxiliary construction). . . . .174
9.5.4 Dimension Tables. . . . .174
9.5.5 General Principles of Cladding Assembly . . . . .177
9.6 Wall and Ceiling cladding with Fire Protection Effect . . . . .181
9.6.1 Test procedure for fire protective cladding . . . . .181
9.6.2 Cladding with CETRIS® Cement Bonded Particleboard with Fire Protection Effects . . . . .181
9.6.3 General Principles of Assembly of Cladding of CETRIS® Cement Bonded Particleboard with Fire Protection Effects . . .181
9.7 Light Composed Roofing. . . . .182
9.7.1 Introduction . . . . .182
9.7.2 Fire Characteristics. . . . .182
9.7.3 General Principles of Assembly . . . . .182
<b>10 Other applications of CETRIS® boards</b>
10.1 Use of CETRIS® boards in engineering and transport constructions . . .186
10.2 System of permanent shuttering . . . . .188
10.2.1 Advantages of permanent shuttering. . . . .189
10.2.3 Ceiling elements . . . . .190
10.3 Application of CETRIS® AKUSTIC cement bonded particle board . . .191
<b>11 Contacs</b>
11.3 Contacts on technical and sales departments of CETRIS division . . .200
11.2 List of mentioned manufacturers . . . . .202

## Introduction

1

## Manufacturing Programme

2

## Basic Properties of zementgebundenen Spanplatten CETRIS®

3

## Processing of zementgebundenen Spanplatten CETRIS®

4

## Fastening of zementgebundenen Spanplatten CETRIS®

5

## Surface Finishes of zementgebundenen Spanplatten CETRIS®

6

## CETRIS® Floor Systems

7

## CETRIS® Façade Systems

8

## Application of CETRIS® Boards in Fire Protection pursuant to EN Standards

9

## Other applications of CETRIS® boards

10

## Contacs

11

„Even the best materials used in a perfect system do not by themselves guarantee absolute perfection of the construction. That is why it is very important for the site managers, assembly companies and especially the craftsmen themselves to take proper care to duly and consistently work in compliance with the prescribed technological procedures and contact us, the manufacturer of the CETRIS® cement bonded particleboards, with trust in the case of any doubt. All our colleagues are ready to provide any information that might help you resolve any particular problem.

We believe that mutual exchange of experience between the manufacturer of CETRIS® cement bonded particleboards and the customer will contribute to the successful implementation of the customer's construction work.“

Introduction of Company	1.1
Quality Policy of CETRIS® Division	1.2
References	1.3



## 1.1 Introduction of Company

The company CIDEM Hranice, a.s., division CETRIS®, is currently the biggest manufacturer of cement bonded particleboards in Europe.



Construction of the factory for manufacture of cement bonded particleboard in the Czech Republic was commenced in 1987. The plant was commissioned in 1991.

In the first years of production the product range was limited only on a motherboard CETRIS® BASIC without surface treatment. The product range was gradually extended, and more services were added, such as cutting, milling, grinding, drilling, application of surface coatings, and more. At present we offer a total of eleven kinds of cement bonded particleboards, and we are continuously developing new types of products in order to satisfy the needs and desires of our customers.

The growing popularity and versatility of CETRIS® boards proved by the fact that they are currently being exported to almost all over Europe, and also to Africa, Asia and South America.

The cement bonded particleboards CETRIS® are manufactured on technological equipment provided by a German company BISON. In 2010, the production line underwent extensive overall renovations with the aim of improving and increasing of production capacity, which is currently 55,000 m<sup>3</sup> per year. The production line is newly fitted with cleaning and polishing equipment that perfectly clean production areas and thus improves the quality of board surface. The drying chamber was renovated and extended, and new formatting saw was purchased. When formatting the manufactured boards, we are now able to declare lower values of permitted tolerances in dimensions and shapes, which are significantly below the standard values. The surface-coating line also underwent many changes. A fully automated line with spraying machine KRONOS from Italian manufacturer MAKOR was purchased. It perfectly coats not only the visible face side of the board, but also its edges.

At the beginning of the whole process of expanded and enhanced surface coatings procedure we can find cleaning and sanding equipment for the preparation of the face side area, and also efficient drying and cooling equipment. Furthermore, the compressor station was modernized, the dispatch hall was enlarged, and in the future we plan to invest in further modernization and expansion of our plant.

Permanent attention has been paid to the quality of our products. In 1996 our company was certified pursuant to ISO 9002 issued by the accredited international certifier Lloyd's Register Quality Assurance. After the release of the new standard, the system was re-certified in 2003 pursuant to ISO 9001. The manufacturing of cement bonded particleboards CETRIS® is also authorized and supervised by Notified Bodies. Since the company exports its products throughout Europe, the cement bonded particleboards are certified not only according to the European harmonized standards, but also according to national standards.



## 1.2 Quality Policy of CETRIS® Division

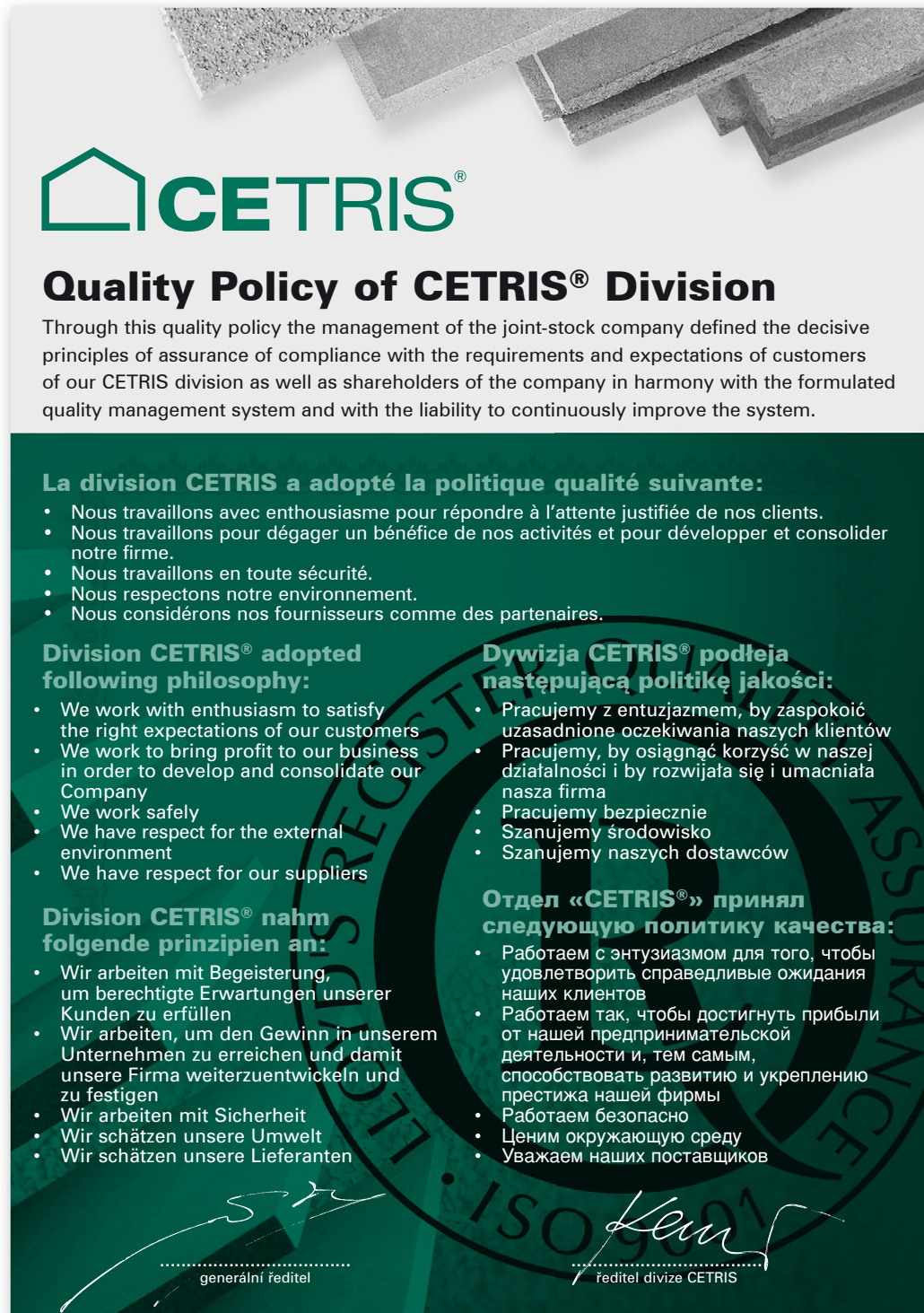

**CETRIS®**

### Quality Policy of CETRIS® Division

Through this quality policy the management of the joint-stock company defined the decisive principles of assurance of compliance with the requirements and expectations of customers of our CETRIS division as well as shareholders of the company in harmony with the formulated quality management system and with the liability to continuously improve the system.

**La division CETRIS a adopté la politique qualité suivante:**

- Nous travaillons avec enthousiasme pour répondre à l'attente justifiée de nos clients.
- Nous travaillons pour dégager un bénéfice de nos activités et pour développer et consolider notre firme.
- Nous travaillons en toute sécurité.
- Nous respectons notre environnement.
- Nous considérons nos fournisseurs comme des partenaires.

**Division CETRIS® adopted following philosophy:**

- We work with enthusiasm to satisfy the right expectations of our customers
- We work to bring profit to our business in order to develop and consolidate our Company
- We work safely
- We have respect for the external environment
- We have respect for our suppliers

**Division CETRIS® nahm folgende prinzipien an:**

- Wir arbeiten mit Begeisterung, um berechtigte Erwartungen unserer Kunden zu erfüllen
- Wir arbeiten, um den Gewinn in unserem Unternehmen zu erreichen und damit unsere Firma weiterzuentwickeln und zu festigen
- Wir arbeiten mit Sicherheit
- Wir schätzen unsere Umwelt
- Wir schätzen unsere Lieferanten

**Dywizja CETRIS® podlega następująca politykę jakości:**

- Pracujemy z entuzjazmem, by zaspokoić uzasadnione oczekiwania naszych klientów
- Pracujemy, by osiągnąć korzyść w naszej działalności i by rozwijała się i umacniała nasza firma
- Pracujemy bezpiecznie
- Szanujemy środowisko
- Szanujemy naszych dostawców

**Отдел «CETRIS®» принял следующую политику качества:**

- Работаем с энтузиазмом для того, чтобы удовлетворить справедливые ожидания наших клиентов
- Работаем так, чтобы достигнуть прибыли от нашей предпринимательской деятельности и, тем самым, способствовать развитию и укреплению престижа нашей фирмы
- Работаем безопасно
- Ценим окружающую среду
- Уважаем наших поставщиков

.....  
generální ředitel

.....  
ředitel divize CETRIS

## 1.3 References

For more references see our new colour catalogue "CETRIS® – referenční stavby a aplikace" (CETRIS® – Reference Constructions and Applications) or visit [www.cetris.cz](http://www.cetris.cz), section "References".





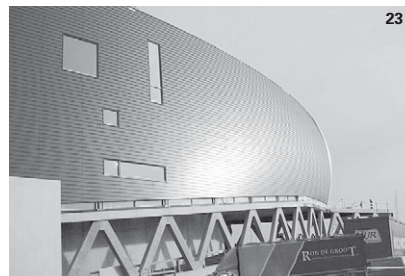
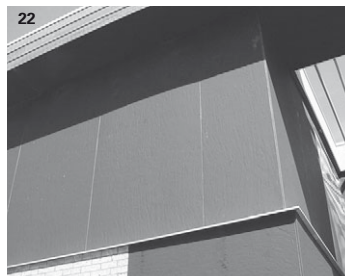

**Fig. 1, 23, 33** LUXOR theatre, Rotterdam, the Netherlands  
CETRIS® FINISH, façade cladding, PLANK system

**Fig. 2, 3** Family house, Czech Republic  
CETRIS® BASIC, construction panels

**Photo 4** Flooring, Olomouc, Czech Republic  
Floating floor IZOCET

**Fig. 5, 27** Tennis hall, Prague – Trója, Czech Republic  
CETRIS® FINISH, façade cladding, PLANK system



**Photo 6** Administrative building SPORTEN, Nové Město, Czech Republic  
CETRIS® BASIC, façade cladding, VARIO system

**Photo 7** Administrative building J&T, Bratislava, Slovak Republic  
CETRIS® FINISH, façade cladding, VARIO system

**Fig. 8, 10** Residential block, Austria  
CETRIS® BASIC, construction panels  
VST-permanent formwork



**Fig. 9, 26** Family house, Prague, Czech Republic  
CETRIS® BASIC, façade cladding, PLANK system

**Fig. 11, 17, 36** Czech House, Malmö, Sweden  
CETRIS® FINISH, façade cladding, VARIO system

**Photo 12** Family House, Slavkov, Czech Republic  
CETRIS® BASIC, construction panels

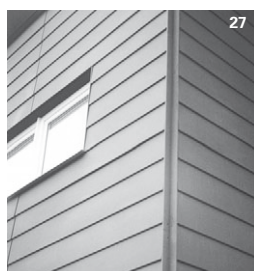

**Photo 13** Entrance gate to a manufacturing plant, Brno, Czech Republic  
CETRIS® FINISH, façade cladding, VARIO system

**Photo 14** Family housing, the Netherlands  
CETRIS® FINISH, soffits

**Photo 15** Flowerbed curb, Czech Republic  
CETRIS® BASIC, HOBBY system

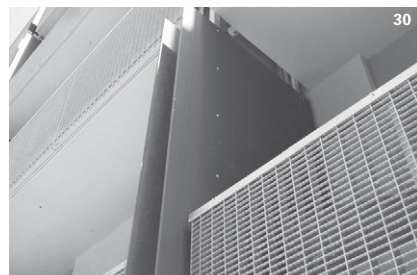

**Photo 16** Family house, Nijmegen, the Netherlands  
CETRIS® BASIC, visible construction panels – interior, staircase, ceilings

**Photo 18** Grammar school at Will, Switzerland  
CETRIS® BASIC, ceiling and flooring constructions, sound insulation (drilled) CETRIS® boards

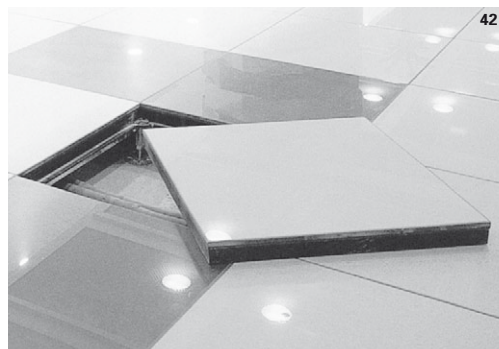

**Photos 19, 28, 30, 41** Residential complex, Nový Prosek, Czech Republic  
CETRIS® FINISH, CETRIS® BASIC, façade cladding, ceiling panels, VARIO system

**Photo 20** Family house, Hranice, Czech Republic  
CETRIS® DOLOMIT, soffits, ceiling panels

**Photo 21** Family housing, the Netherlands  
CETRIS® PROFIL FINISH, façade cladding, PLANK system

**Photo 22** Family house, the Netherlands  
CETRIS® PROFIL FINISH, slate relief type, façade cladding, VARIO system

**Photos 24, 40** Terrace family houses, Roosendaal, the Netherlands  
CETRIS® BASIC, construction system

**Photo 25** Residential complex, Kristof Piazza, Trenčianske Teplice, Slovak Republic  
CETRIS® BASIC, permanent formwork

**Photo 29** Family housing, Brno – Žebětín, Czech Republic  
CETRIS® FINISH and CETRIS® PROFIL FINISH cladding, slate relief type

**Photo 31** Administrative building, the Netherlands  
CETRIS® FINISH, window inserts

**Photo 32** Brewery, Přerov, Czech Republic  
CETRIS® PROFIL FINISH, ceiling panels, wood-look relief type

**Photo 34** Family house, Říčany, Czech Republic  
CETRIS® FINISH, façade cladding, VARIO system

**Photos 35, 37** Administrative building of the Múpo Company, Brno, Czech Republic  
CETRIS® BASIC, CETRIS® FINISH, façade cladding, VARIO system

**Photo 39** Family house, Oosthozien, the Netherlands  
CETRIS® PROFIL FINISH, façade cladding, PLANK system

**Photos 38, 42** Administrative building flooring, Italy  
CETRIS® NESITE, elevated floor, wooden surface

Manufacturing of CETRIS® cement bonded particleboard	2.1
Merits of CETRIS® cement bonded particleboards	2.2
Composition of CETRIS® cement bonded particleboards	2.3
Types of CETRIS® cement bonded particleboards	2.4
Packaging, Storage and Handling	2.5
Parameters of Shipped Boards	2.6

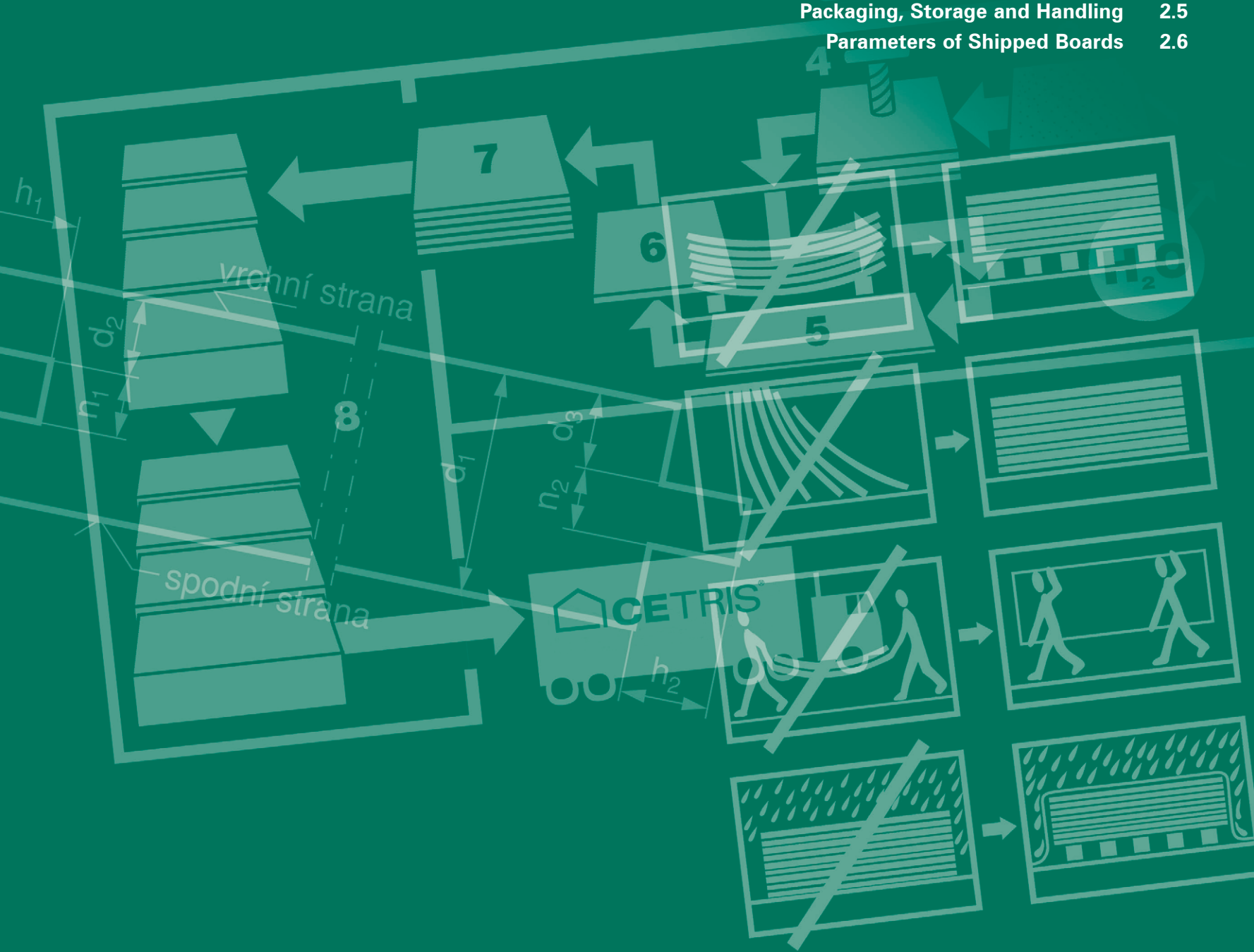

## 2 Manufacturing Programme

CETRIS® cement bonded particleboard is a high-standard board material of exceptional properties for flooring systems, attics, roofing, vented façades, fire protection applications, ceiling panels, walls and partitions and garden accessories.

CETRIS® cement bonded particleboard application areas include assembled constructions of all kinds. They are ideal for dry construction applications, for constructions under demanding climatic conditions and wherever other favourable features of this construction material may fully manifest themselves.



### 2.1 Manufacturing of CETRIS® cement bonded particleboard

CETRIS® cement bonded particleboards are manufactured by a technology supplied by the German company BISON. In 2010 the manufacturing line underwent an overall reconstruction including modernisation of the machinery and the increase of manufacturing capacity to 55,000 m<sup>3</sup> a year.

#### Simplified manufacturing procedure:

- 1 Chipping
- 2 Mixture mixing
- 3 Board layering
- 4 Pressing and hardening under pressure
- 5 Maturation and drying
- 6 Trimming
- 7 Storage
- 8 Shipment

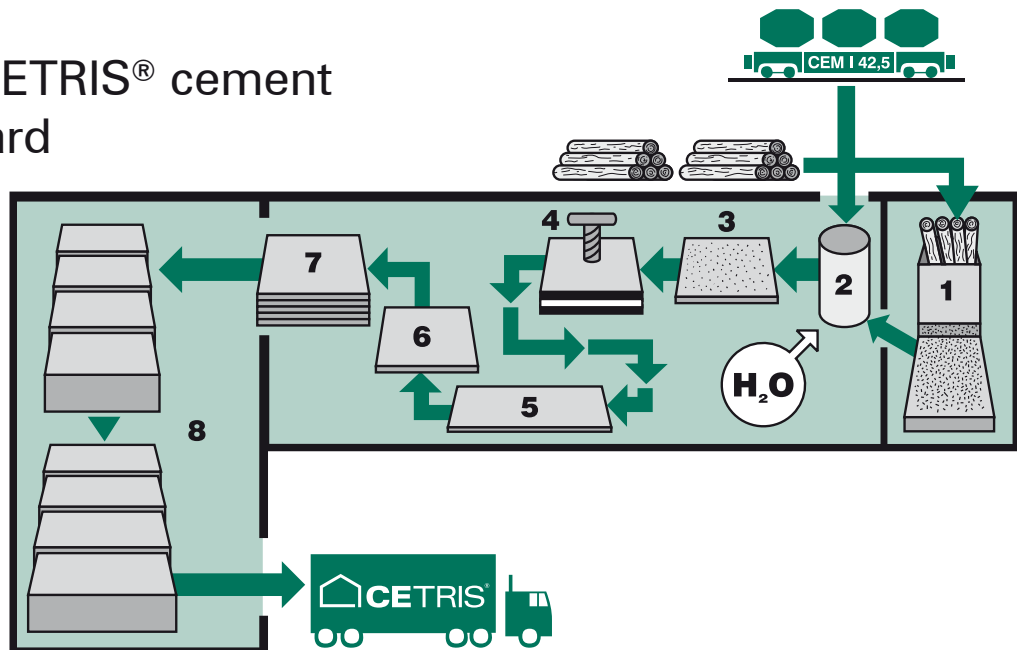

CETRIS® cement bonded particleboards are made in compliance with EN 633, 634-1 and 634-2.

Debarked spruce and fir timber is stored for three to four months and then chipped to needle-shaped chips and transported to silos. The prepared wooden mass is dosed in the mixing device to be mixed with quality Portland cement. Further ingredients added pursuant to the recipe include mineralising substances and water whose quantity is adapted to the measured timber humidity. In the layering device the mixed material is spread over flat, pre-treated steel trays. The device works with four separated

layering machines in a row. The first and the fourth chamber create the cover layers of the boards with the help of wind sorting. The second and the third chamber are mechanical and are used for creation of the middle layer by even application. The middle layer is bonded. The trays with the bonded material are stacked and pressed under high pressure to the nominal board thickness (about one third of the spreading thickness). Following an accelerated hydration process of hardening, the boards are

de-stacked and transferred to an air-conditioned warehouse where they mature for at least seven days. After that the CETRIS® boards are dried to the humidity of 9% (±4 weight %). Then the boards are trimmed to basic dimensions. Further services are performed on customer request, including board cutting to smaller sizes, edge milling, edge chamfering, drilling, grinding, priming and other surface finishes.

## 2.2 Merits of CETRIS® cement bonded particleboards

CETRIS® cement bonded particleboards combine positive properties of cement and wood. They are lighter than the traditional cement fibreboards, and their compactness and weather resistance, frost and mould resistance place them above cement bonded chipboards or plasterboards.

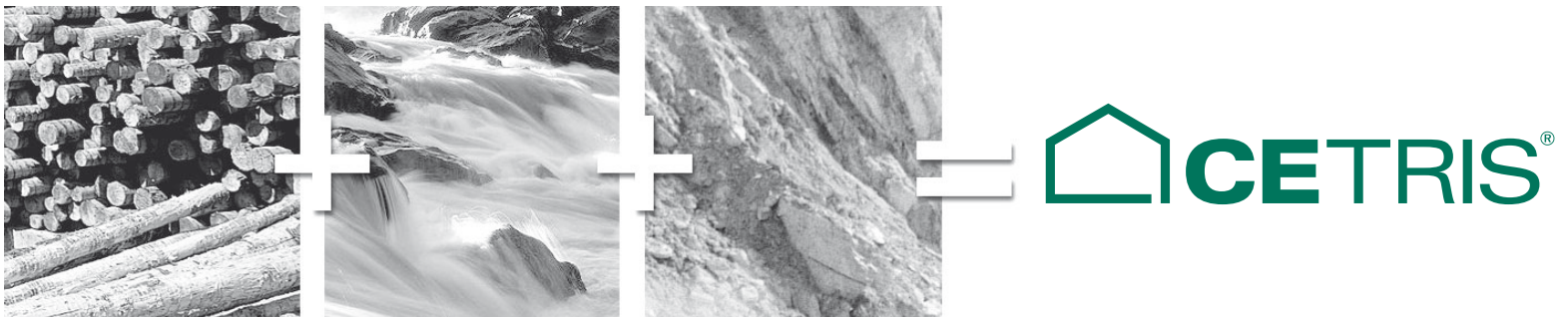

### Principal benefits of CETRIS® boards

#### Environment Friendliness



Cement bonded particleboards are environment friendly. They do not contain hazardous substances such as asbestos or formaldehyde and are resistant to petrol and oils.

#### Frost Resistance



CETRIS® cement bonded particleboards have been tested using the 100 freezing cycle test pursuant to EN 1328.

#### Low Weight



CETRIS® boards are light (10 mm thick boards weigh only 14.0 kg/m<sup>2</sup>).

#### Fire Resistance



CETRIS® cement bonded particleboards are fire resistant and classified pursuant to the reaction to fire class pursuant to the European standard EN 13501-1 as A2-s1, d0 – non flammable.

#### No Hygienic Risks



CETRIS® boards cause no hygienic risk, do not stink and do not contain any hazardous substances.

#### Flexibility



Elasticity module of a CETRIS® board is <math><4,500\text{ N/mm}^2</math>.

#### Moisture Resistance



CETRIS® cement bonded particleboards are ideal for humid environments including exteriors thanks to their moisture resistance. Thickness swelling, after immersing CETRIS® boards in water for 24 hours, is only max. 1.5 %.

#### Mould Resistance



Thanks to the resistance of CETRIS® boards against humidity no mould develops on their surface.

#### Easy Processing



CETRIS® cement bonded particleboards may be processed by any wood processing machinery. The boards may be drilled, cut, milled and sanded.

#### Perfect Sound Barrier



CETRIS® boards absorb sound (airborne sound transmission loss 30 – 35 dB).

#### Insect Resistance



Due to their cement content the CETRIS® cement bonded particleboards are absolutely insect resistant.

## 2.3 Composition of CETRIS® cement bonded particleboards

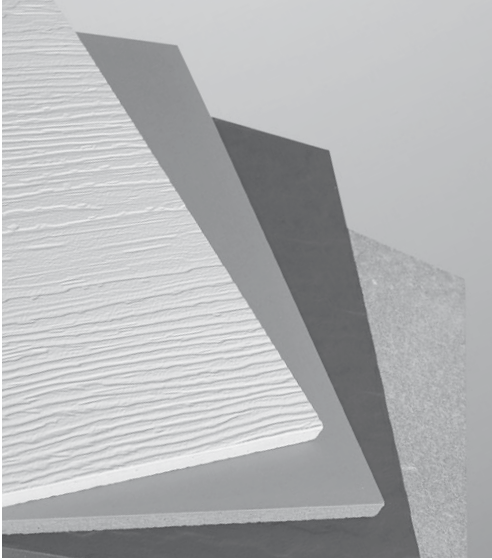

CETRIS® boards are composed of wooden mass, cement, water and hydration admixtures in the following proportions:

The board structure is formed by pressing the wooden particles coated with cement. The finer fraction is applied on both sides of the middle coarse fraction. That is why the board surface is smooth.

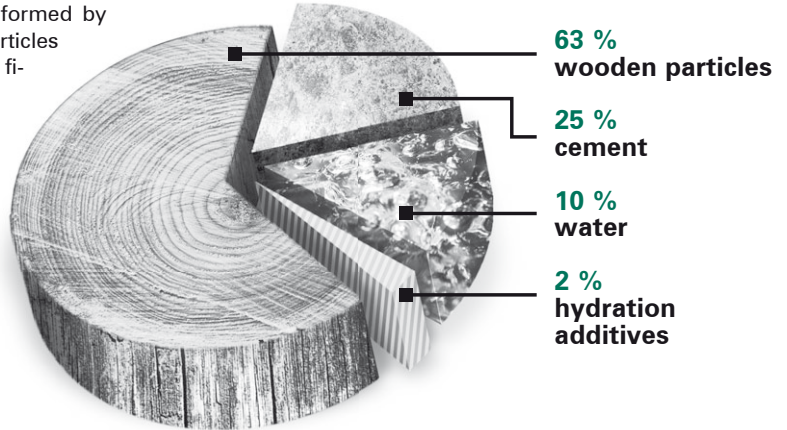

## 2.4 Types of CETRIS® cement bonded particleboards

### Boards without surface finish

#### 2.4.1 CETRIS® BASIC

Cement bonded particleboard with smooth cement grey surface. Standard thicknesses of 8, 10, 12, 14, 16, 18, 20, 22, 24, 26, 28, 30, 32 mm, or 34, 36, 38 and 40 mm on request. The basic board size is 3,350 by 1,250 mm. The boards are supplied to the customer cut to the required dimensions, with rounded or chamfered edges (45 degrees chamfer), milled from 12 mm thickness up with semi-groove or from 16 mm up with groove and tongue. Holes may also be pre-drilled in the boards on request.



CETRIS® BASIC	cement bonded particleboard with smooth natural cement grey surface
Basic size	1,250 × 3,350 mm
Board thickness	8, 10, 12, 14, 16, 18, 20, 22, 24, 26, 28, 30, 32 mm (on request 34, 36, 38, 40 mm)
Bulk density	1,150 – 1,450 kg/m <sup>3</sup>
Services	on customer request – cutting, milling, hole drilling, edge chamfering
Relief type	smooth
Surface finish	none

Size tolerances (all data in mm):

CETRIS® BOARD THICKNESS	Limit tolerances for 1 <sup>st</sup> class quality		
	Thickness	Width	Length
8, 10	± 0.7	± 5	± 5
12, 14	± 1.0	± 5	± 5
16, 18	± 1.2	± 5	± 5
20, 22, 24, 26, 28, 30, 32, 34, 36, 38, 40	± 1.5	± 5	± 5

The tolerances of width and length ±5 mm are according to the standard. The actual tolerances of finished products range around ±2 mm.

### 2.4.2 CETRIS® PD

Cement bonded particleboard, size 1,250 by 625 mm (including tongue) for dry flooring technologies. Standard thicknesses of 16, 18, 20, 22, 24, 26, 28 mm, or other thicknesses and sizes on request. The boards are provided with groove and tongue on the perimeter and are designed for laying over beams or for renovation of old floors.

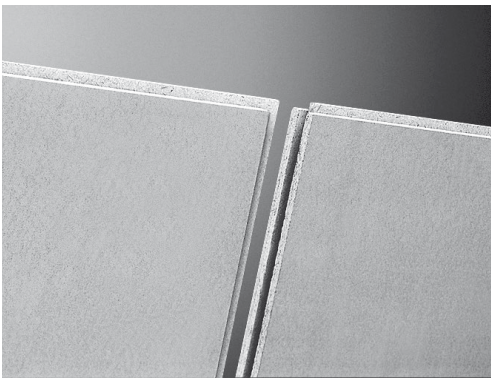

CETRIS® PD	cement bonded particleboard with groove and tongue with smooth surface
Basic size	625 × 1,250 mm (including tongue)
Board thickness	16, 18, 20, 22, 24, 26, 28 mm (on request 30, 32 mm)
Bulk density	1,150 – 1,450 kg/m <sup>3</sup>
Services	milled edges – groove and tongue
Thickness tolerances	±1,2 mm (for thickness of 16 and 18 mm), ±1,5 mm (for the other)
Surface finish	none

### 2.4.3 CETRIS® PDB

Cement bonded particleboard, calibrated by sanding, size 1,250 by 625 mm for dry flooring technologies. The calibration reduces thickness tolerance to ±0.3 mm. Standard thicknesses of 16, 18, 20, 22, 24, 26, 28 mm, or other thicknesses and sizes on request. The boards are provided with groove and tongue on the perimeter and are designed for laying over beams or for renovation of old floors.

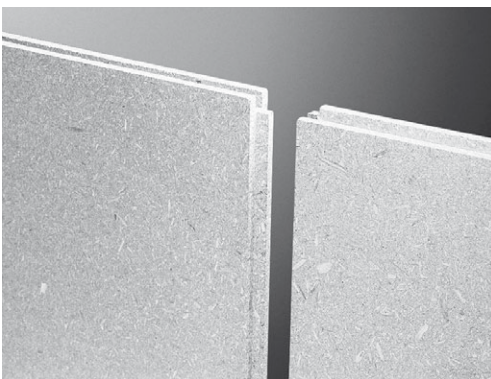

CETRIS® PDB	ground cement bonded particleboard with groove and tongue with smooth surface
Basic size	625 × 1,250 mm (including tongue)
Board thickness	16, 18, 20, 22, 24, 26, 28 mm (on request 30, 32 mm)
Bulk density	1,150 – 1,450 kg/m <sup>3</sup>
Services	milled edges – groove and tongue, sanding
Thickness tolerances	±0.3 mm
Surface finish	none

Dimensions of CETRIS® PD and CETRIS® PDB boards groove and tongue (all data in mm)

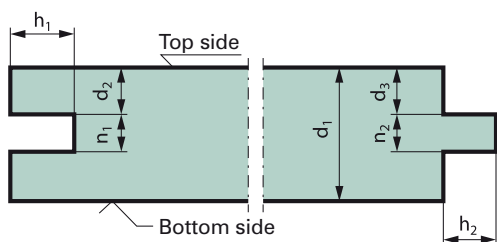

	16	18	20	22	24	26	28
d <sub>1</sub>	16	18	20	22	24	26	28
n <sub>2</sub>	5.5	5.5	5.5	5.5	7.0	7.0	7.0
n <sub>1</sub>	6.0	6.0	6.0	6.0	8.0	8.0	8.0
d <sub>2</sub>	5.0	6.0	7.0	8.0	8.0	9.0	10.0
d <sub>3</sub>	5.25	6.25	7.25	8.25	8.5	9.5	10.5
h <sub>1</sub>	10.0	10.0	10.0	10.0	10.0	10.0	10.0
h <sub>2</sub>	8.5	8.5	8.5	8.5	8.5	8.5	8.5

## 2.4.4 CETRIS® PDI

CETRIS® PDI is a two-ply panel used in dry floor technology. It consists of a 22 mm thick cement bonded CETRIS® particleboard glued to 12 mm insulating fibreboard (hardboard). The size is 1,220 × 610 mm (including the tongue) and it is 34 mm thick; it has a tongue and groove along the perimeter, the surface is smooth. The panels should be laid on a level surface area (ceiling structures, cladding). They are great for a quick and exact installation. They also spread spot-load stress over a larger area.

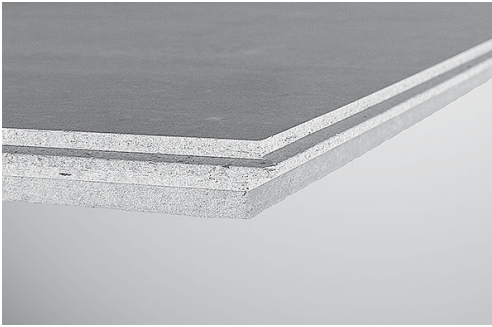

<b>CETRIS® PDI</b>	Two ply panel of cement bonded particleboard CETRIS® glued together with insulating wood-fibre board.
Basic size	1,220 × 610 mm (with tongue), 1,203 × 593 mm (without tongue). Panel size after laying: 0.713 m <sup>2</sup>
Rough dimensional tolerance	± 1.5 mm
Thickness	34 mm
Weight	ca 33.5 kg/m <sup>2</sup>
Features	Tongue & groove shaped edges
Surface finish	Without surface finish

## 2.4.5 CETRIS® PROFIL

Cement bonded particleboard, thickness 10 or 12 mm, with relief surface imitating wood or slate structures. The basic board size is 3,350 by 1,250 mm. The services provided are the same as in the case of CETRIS® BASIC boards. For their decorative appearance these boards are mainly used as façade cladding, interior as well as exterior.

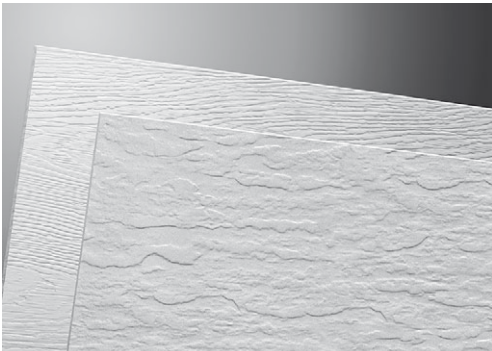

<b>CETRIS® PROFIL</b>	cement bonded particleboard with relief and cement grey surface
Basic size	1,250 × 3,350 mm
Board thickness	10, 12 mm
Bulk density	1,150 – 1,450 kg/m <sup>3</sup>
Services	on customer request – cutting, hole drilling, edge chamfering
Relief type	slate, wood
Surface finish	none



## 2.4.6 CETRIS® AKUSTIC

CETRIS® AKUSTIC cement bonded particleboard is made by processing (drilling of regularly spaced holes with the diameter of 12 mm) in the CETRIS® BASIC board type. The standard board size is 1,250 by 625 mm and the thickness is 8 and 10 mm. The board surface is smooth, cement grey (without surface finish).

Drilling of regularly spaced holes achieves, in addition to the existing high mechanical strength values, improved acoustic properties. CETRIS® AKUSTIC

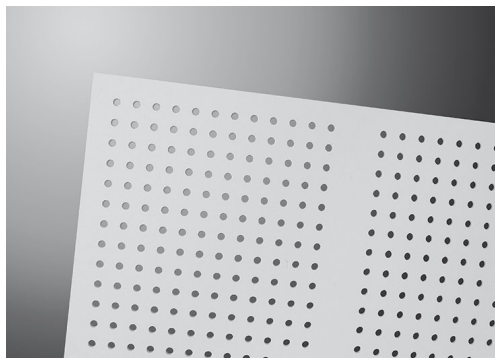

<b>CETRIS® AKUSTIC</b>	cement bonded particleboard with predrilled holes and smooth cement surface
Basic size	1,250 × 625 mm with drilled holes – diameter 12 mm, spacing 30 – 32 mm (see figure)
Board thickness	8, 10 mm (on request 12, 14, 16 and 18 mm)
Bulk density	1,150 – 1,450 kg/m <sup>3</sup>
Area density	Thickness 8 mm – 10 kg/m <sup>2</sup> , thickness 10 mm – 12.5 kg/m <sup>2</sup>
Surface finish	none

is a board used for acoustic cladding especially in sporting facilities, spaces with varying temperature and humidity and special demand buildings.

improving the space acoustics and contributing to noise absorption in the interiors.

Installing the CETRIS® AKUSTIC cement bonded particleboard in a wall cladding system or ceiling panel system (under ceiling or roof construction) together with the load-bearing structure, acoustically effective textile and mineral wool inserts results in an aesthetically attractive as well as functional cladding,

For details of use of CETRIS® AKUSTIC board see Chapter 10.4.

## Boards with surface finish

### 2.4.7 CETRIS® PLUS

Cement bonded particleboard, size 8 – 32 mm, with smooth surface. On request thicknesses of 34, 36, 38 and 40 mm may be supplied. Both sides and all edges are primed with a white primer. The paint on the face side is applied in two layers. The basic board size is 3,350 by 1,250 mm. The services provided are the same as in the case of CETRIS® BASIC boards. The primer improves adhesion between the board and the final surface finish, reduces the board absorption rate and consumption of the top coat material.

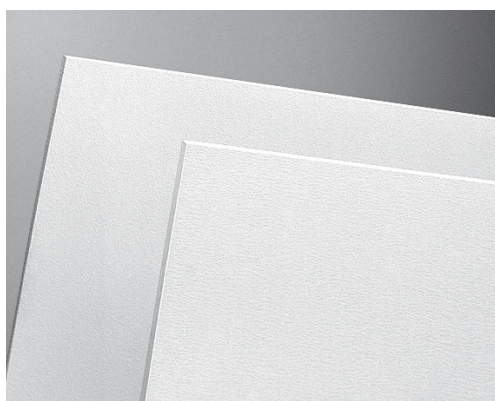

<b>CETRIS® PLUS</b>	cement bonded particleboard with smooth surface and primer
Basic size	1,250 × 3,350 mm
Board thickness	8, 10, 12, 14, 16, 18, 20, 22, 24, 26, 28, 30, 32 mm
Bulk density	1,150 – 1,450 kg/m <sup>3</sup>
Services	on customer request – cutting, hole drilling, edge chamfering
Surface finish	primer
Colour Shade	colour shade – white or RAL on request

## 2.4.8 CETRIS® PROFIL PLUS

Cement bonded particleboard, thickness 10 or 12 mm, with relief surface imitating wood or slate structures. Both sides and all edges are primed with a white primer, which improves adhesion between the board and the final surface finish, reduces the board absorption rate and consumption of the top coat material. The basic board size is 3,350 by 1,250 mm. The services provided are the same as in the case of CETRIS® BASIC boards.

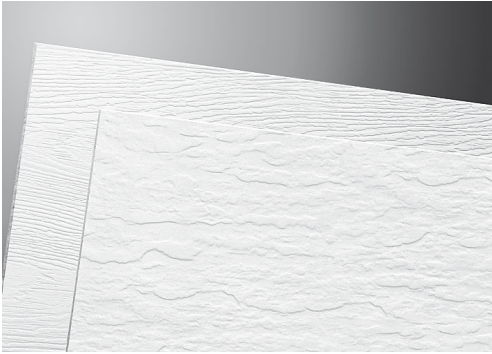

CETRIS® PROFIL PLUS	cement bonded particleboard with relief and primer
Basic size	1,250 × 3,350 mm
Board thickness	10, 12 mm
Bulk density	1,150 – 1,450 kg/m <sup>3</sup>
Relief type	slate, wood
Services	on customer request – cutting, hole drilling, edge chamfering
Surface finish	primer (one or two layers)
Colour Shade	colour shade – white or RAL on request

## 2.4.9 CETRIS® FINISH

Cement bonded particleboard, thickness 10–32 mm, with smooth surface, primer and top coat in RAL or NCS shades. On request thicknesses of 34, 36, 38 and 40 mm may be supplied. The basic board size is 3,350 by 1,250 mm. The services provided are the same as in the case of CETRIS® BASIC boards. The CETRIS® FINISH boards are mainly used as exterior façade cladding.

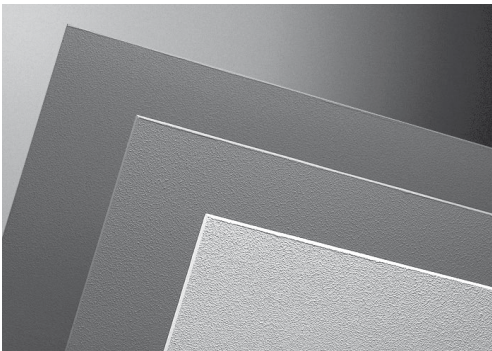

CETRIS® FINISH	cement bonded particleboard with smooth surface, primer and top coat pursuant to pattern book
Basic size	1,250 × 3,350 mm
Board thickness	10, 12, 14, 16, 18, 20, 22, 24, 26, 28, 30, 32 mm
Bulk density	1,150 – 1,450 kg/m <sup>3</sup>
Relief type	smooth
Services	on customer request – cutting, milling, hole drilling, edge chamfering
Surface finish	primer, top coat
Colour Shade	pursuant to RAL or NCS colour tables (consult the manufacturer for a suitable shade)

## 2.4.10 CETRIS® PROFIL FINISH

Cement bonded particleboard, thickness 10 or 12 mm, with relief surface imitating slate or wood structures. The board is covered with a primer and top coat in RAL or NCS shades. The basic board size is 3,350 by 1,250 mm. The services provided are the same as in the case of CETRIS® BASIC boards. The CETRIS® PROFIL FINISH boards are mainly used as exterior and interior façade cladding.

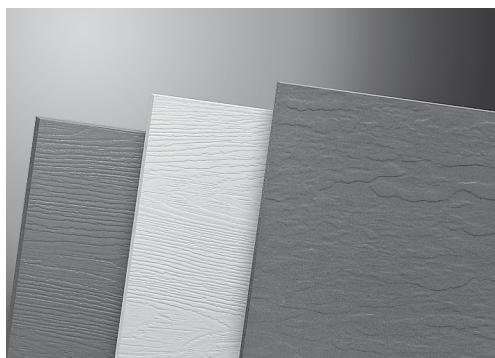

<b>CETRIS® PROFIL FINISH</b>	cement bonded particleboard with relief surface, primer and top coat pursuant to colour chart
Basic size	1,250 × 3,350 mm
Board thickness	10, 12 mm
Bulk density	1,150 – 1,450 kg/m <sup>3</sup>
Relief type	slate, wood
Services	on customer request – cutting, hole drilling, edge chamfering
Surface finish	primer, top coat
Colour Shade	pursuant to RAL or NCS colour charts (consult the manufacturer for a suitable shade)

## 2.4.11 CETRIS® LASUR

Cement bonded particleboard in thickness ranging from 10 – 32 mm with smooth surface, treated with primer paint and acrylic varnish glazing as the top coat in colours as per the colour chart. The glazing top coat provides a solid but non-uniform appearance. Upon prior agreement it is also possible to deliver the following thicknesses: 34, 36, 38 and 40 mm. The basic size of the board is 3 350 × 1250 mm. We provide the same services as for the CETRIS® BASIC boards. The CETRIS® LASUR boards are primarily used as exterior facade sheathing boards.

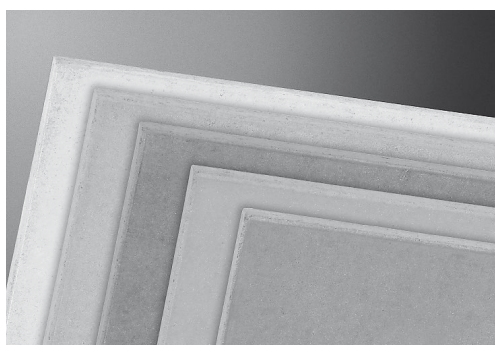

<b>CETRIS® LASUR</b>	Cement bonded particleboard in thickness ranging from 10 – 32 mm with smooth surface, treated with primer paint and acrylic varnish glazing as the top coat in colours as per the colour chart.
Basic size	3,350 × 1,250 mm
Board thickness	10, 12, 14, 16, 18, 20, 22, 24, 26, 28, 30 a 32 mm (upon prior agreement 34, 36, 38, 40 mm)
Bulk density	1,150 – 1,450 kg/m <sup>3</sup>
Relief type	smooth
Services	on customer request – cutting, hole drilling, edge chamfering
Surface finish*	pigmented primer, varnish glazing top coat
Colour Shade	as per the colour chart* for CETRIS® LASUR boards (7 shades)

\* Note: The back side of CETRIS® LASUR cement bonded particleboards is treated with primer coat without a regular texture, look and sufficient covering power. The colour shade of the coat is not specific, therefore the requirement for a white or transparent shade needs to be specified in the order in advance.

## 2.4.12 CETRIS® AKUSTIC FINISH

The cement-bonded particleboard CETRIS® AKUSTIC FINISH is the result of treatment (drilling of evenly spaced 12-mm diameter holes) of the CETRIS® BASIC basic board type. The basic dimension of the particleboard is 1,250 × 625 mm, the product is 8 or 10 mm thick. The particleboard surface is treated with a primer coat and then a final surface coat according to RAL or NCS colour charts is applied.

Present high mechanical parameters are broadened with excellent acoustic parameters by drilling holes in regular patterns.

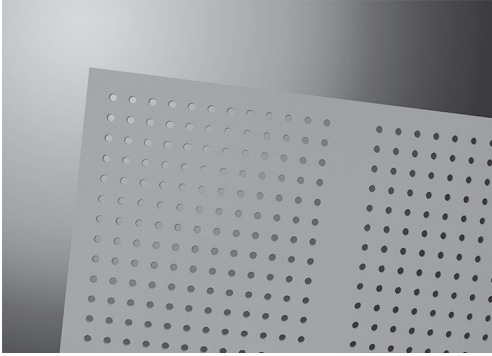

<b>CETRIS® AKUSTIC FINISH</b>	cement bonded particleboard with pre-drilled holes, smooth surface, treated with a primer coat and a surface finish
Basic size	1,250 × 625 mm with drilled holes – diameter 12 mm, spacing 30 – 32 mm (see figure)
Board thickness	8, 10 mm (on request 12, 14, 16 and 18 mm)
Bulk density	1,150 – 1,450 kg/m <sup>3</sup>
Area density	8 mm – 10 kg/m <sup>2</sup> , 10 mm – 12.5 kg/m <sup>2</sup>
Surface finish	primer coat, finish coat
Colour Shade	pursuant to RAL or NCS colour charts (consult the manufacturer for a suitable shade)

The CETRIS® AKUSTIC FINISH represents a sound absorbing cover panel with applications especially in sports facilities, areas with variable temperature and moisture levels, and in buildings with special requirements.

\* Note: The coating the back side does not have a regular structure.

## 2.4.13 CETRIS® DEKOR

Cement bonded particleboard CETRIS® DEKOR is cement bonded particleboard in thickness 12 and 14 mm with smooth surface, treated with primer paint and decorative acrylic mosaic plaster in colours according to a colour chart. The board is used predominantly as exterior facade board.

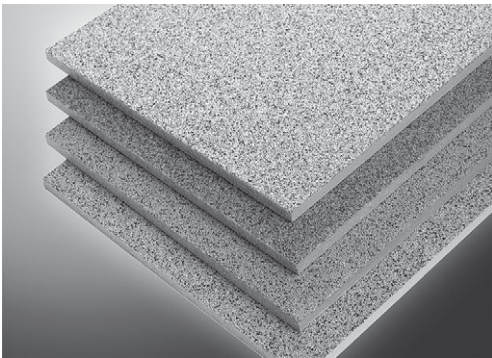

<b>CETRIS® DEKOR</b>	Cement bonded particleboard with smooth surface, treated with surface finish – decorative acrylic mosaic plaster in colours according to a colour chart
Basic size	1,250 × 625 mm (upon agreement also other)
Board thickness	12 and 14 mm (upon agreement also other)
Bulk density	1,150 – 1,450 kg/m <sup>3</sup>
Area density	th. 12 mm – cca 20 kg/m <sup>2</sup> , th. 14 mm – cca 23 kg/m <sup>2</sup>
Relief type	Smooth
Surface finish*	Primer paint and decorative acrylic mosaic plaster
Shades	As per the colour chart for CETRIS® DEKOR boards

\* Note: The back side of cement bonded particleboards CETRIS® DEKOR is coated with a protective white primer, which does not have a regular structure, appearance and sufficient coverage.

## 2.5 Packaging, Storage and Handling



CETRIS® cement bonded particleboards are stored on wooden pallets allowing for forklift handling. The boards are fixed to the pallet by crosswise tying of the boards to the pallet. Lengthwise tying on customer request only.

CETRIS® boards are protected against the weather with PE foil wrap. Wrapping the CETRIS® boards into PE foil does not meet requirements for long-term weather protection in the case of open air storage. Storage may cause bending of the upper board as a result of quicker drying of the upper surface. This effect may be eliminated by turning the board upside down.

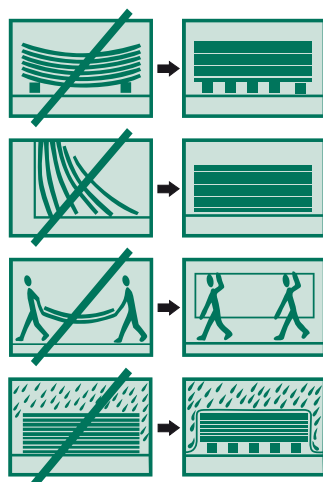

CETRIS® boards should be stored in a roofed dry space to prevent moistening of the boards before installation. The stored pallets with boards of the same size may be stacked up to a max. five layers.

CETRIS® boards should only be handled on the pallets, or in the vertical position. Manual transfers should also be performed in a vertical position.

Board thickness (mm)	Approximate weight (kg/m <sup>2</sup> )	Approximate board weight (kg/pc)	Number of boards on pallet (pc)	Board surface size on pallet (m <sup>2</sup> )	Total approximate weight of boards including pallet (kg)
-------------------------	--	-------------------------------------	------------------------------------	---	---

### CETRIS® cement bonded particleboard in basic format (size 3,350 by 1,250 mm)

8	11.36	47.6	60	251.25	2,894
10	14.2	59.5	45	188.44	2,716
12	17.0	71.4	40	167.50	2,894
14	19.9	83.3	35	146.56	2,954
16	22.7	95.1	30	125.63	2,894
18	25.6	107.0	25	104.69	2,716
20	28.4	118.9	25	104.69	3,013
22	31.5	130.8	20	83.75	2,656
24	34.3	142.7	20	83.75	2,894
26	36.9	154.6	20	83.75	3,132
28	39.8	166.5	15	62.81	2,537
30	42.6	178.4	15	62.81	2,716
32	45.4	190.3	15	62.81	2,894
34	48.3	202.2	15	62.81	3,073
36	51.1	214.1	10	41.88	2,181
38	54.0	226.0	10	41.88	2,300
40	56.8	237.9	10	41.88	2,419

### CETRIS® PD, PDB (size 1,250 by 625 mm)

16	22.7	17.8	50	39.0	895
18	25.6	20.0	45	35.1	906
20	28.4	22.2	40	31.2	895
22	31.5	24.6	35	31.2	868
24	34.3	26.8	35	31.2	946
26	36.9	28.8	30	23.4	865
28	39.8	31.1	30	23.4	932

### CETRIS® cement bonded particleboard IZOCET and POLYCET (size 1,250 by 625 mm)

12 upper board	17.0	13.3	70	54.7	950
12 lower board	17.0	13.3	70	54.7	950

### CETRIS® cement bonded particleboard AKUSTIC and AKUSTIC FINISH (size 1,250 by 625 mm)

8	10.0	7.80	100	78.13	810
10	12.5	9.75	80	62.50	805

### Insulation fibreboard for IZOCET flooring system (size 1,200 by 810 mm)

20	5.0	5.0	50	48.6	260
20	5.0	5.0	150	145.8	745

**Note:** The format and the packaging may change in relation to the supplied assortment of the insulation board manufacturer.

### CETRIS® PDI floorboards (size 1,220 × 610 mm)

34	33.5	24	30	22.32	750
----	------	----	----	-------	-----

## 2.6 Parameters of Shipped Boards

### 2.6.1 Size Tolerances

**Note:** The tolerances are specified pursuant to EN 634-1.

FEATURE	BOARD THICKNESS	TOLERANCE
Thickness of unsanded board	8, 10 mm	±0.7 mm
	12, 14 mm	±1.0 mm
	16, 18 mm	±1.2 mm
	20 – 40 mm	±1.5 mm
Thickness of sanded board		±0.3 mm
Length and width of basic format		±5.0 mm
Accuracy of division for length and width		±3.0 mm
Edge straightness		1.5 mm/m
Rectangularity		2.0 mm/m

### 2.6.2 Appearance

PARAMETER	1ST CLASS QUALITY	2ND CLASS QUALITY
Deflection from the right angle	max. 2 mm/1 m of length	max. 4 mm/1 m of length
Permitted edge damage	max depth 3 mm	max. depth 30 mm
Plane projections	max. 1 mm, size 10 mm	max. 1 mm
Hollows	max. 1 mm, size 10 mm	max. 2 mm
Other		Thin edges, bark in surface, cement inclusions, peeled off edge, surface damage from pallet, edge and corner damage by saw blades.

### 2.6.3 Services

Milling, chamfering, tongue and groove forming tolerances are specified to assure correct function on assembly.

#### Semi-groove

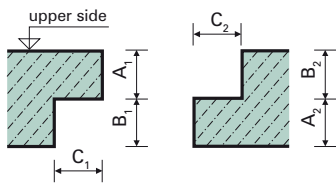

Dimensions	Tolerance	Size	Tolerance
A <sub>1</sub>	-1 / 0	A <sub>2</sub>	-1 / 0
B <sub>1</sub>	0 / +1.5	B <sub>2</sub>	0 / +1.5
C <sub>1</sub>	0 / +2	C <sub>2</sub>	-2 / 0

#### Groove

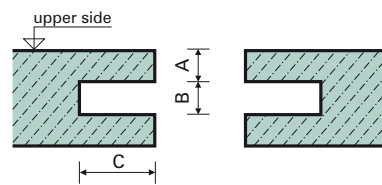

Dimensions	Tolerance
A	-0.5 / +0.5
B	0 / +1.5
C	0 / +2

#### Tongue and groove

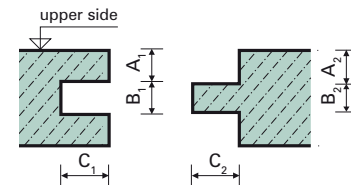

Dimensions	Tolerance	Size	Tolerance
A <sub>1</sub>	±0.5	A <sub>2</sub>	±0.5
B <sub>1</sub>	0 / +0.5	B <sub>2</sub>	-0.5 / 0
C <sub>1</sub>	0 / +2	C <sub>2</sub>	-2 / 0

All dimensions in mm

## Semi-circular groove and tongue

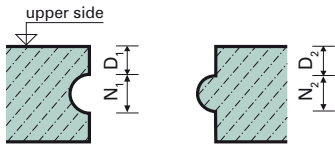

Dimensions	Tolerance	Size	Tolerance
D <sub>1</sub>	±0.5	D <sub>2</sub>	±0.5
N <sub>1</sub>	0 / +0.5	N <sub>2</sub>	-0.5 / 0

## Rounded and chamfered edges

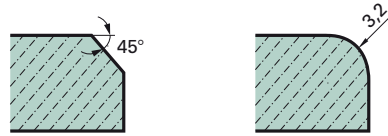

Tolerance
Accuracy of processing ±0.5 mm

## Drilling

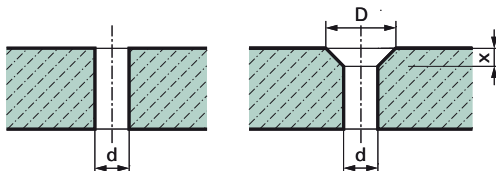

Spacing tolerance of individual drilled holes in the board max. ±5 mm.

DRILLING TYPE	HOLE DIAMETER		SINK DEPTH X (mm)	BOARD THICKNESS (mm)
	d (mm)	D (mm)		
No sink	4.5 – 8.0 ±0.5	-	-	8 – 40
No sink	10.0 – 12.0 ±1.0	-	-	8 – 40
With sink	4.5 ±0.5	9.5 ±0.5	2.5 ±0.5	12 – 40
With sink	5.5 ±0.5	10.0 ±0.5	2.5 ±0.5	12 – 40
With sink	6.5 ±0.5	17.0 ±1.0	5.0 ±1.0	12 – 40

## Surface Finishes

The warranty period for colour stability (by colour manufacturer) is 3 years minimum.

Colour shades of CETRIS® FINISH (FINISH PROFIL) boards may be selected from the RAL or NCS colour table. It is recommended to consult the fitness of the selected colour shade with the manufacturer.

The reverse side of CETRIS® boards with a surface finish is covered with one layer of primer (lacquer) – in standard white or a transparent shade. The protective paint does not cover the identification inscriptions of the boards on the reverse side. The surface of the reverse side of the boards may be slightly damaged by manufacture-related handling of CETRIS® boards.

If on customer request a sample with the required colour shade is produced then this is for colour shade and coverage information only (there is a difference between manual paint application and machine painting of the mass manufactured boards).

## Notes

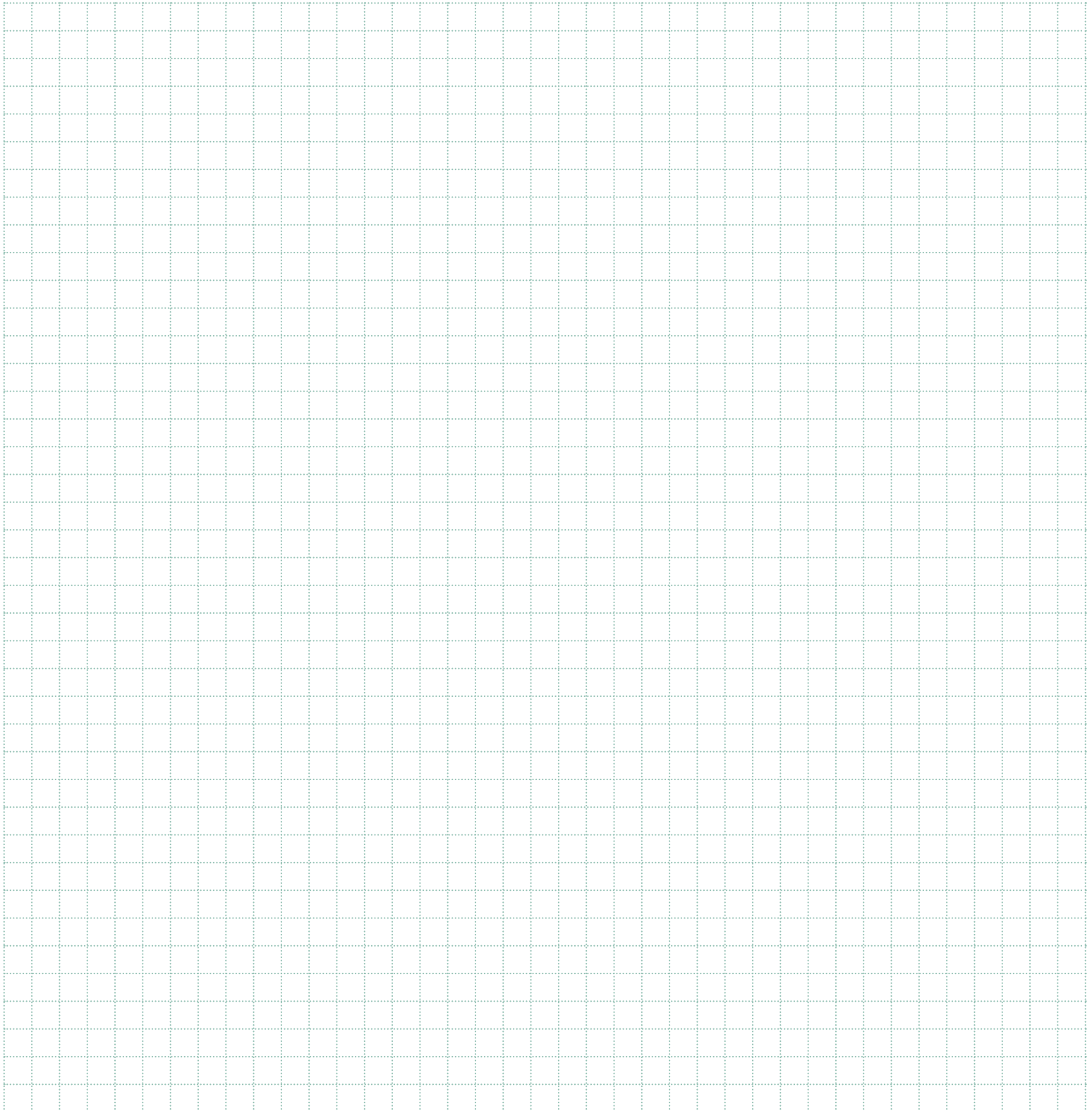



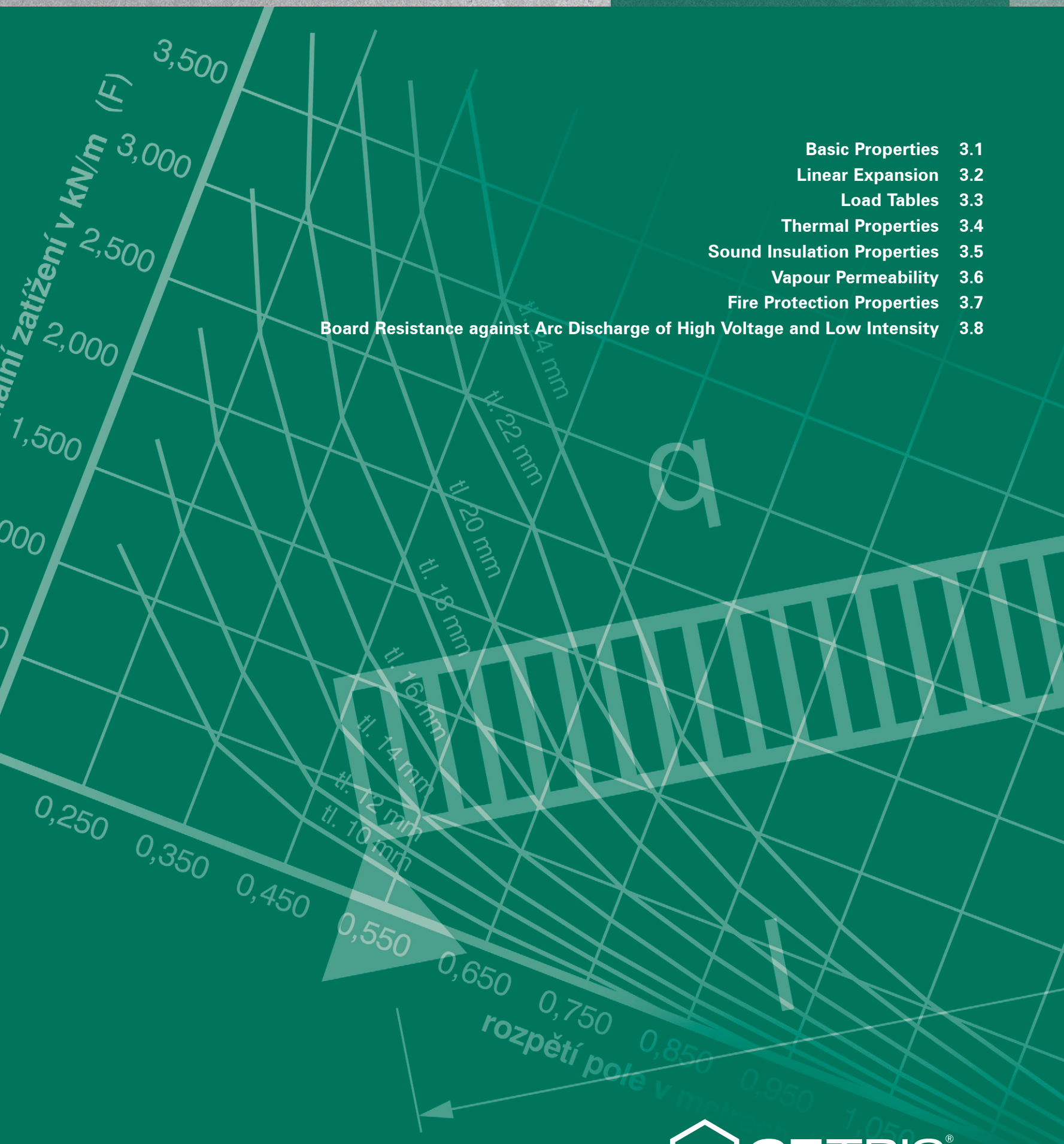

Board Resistance against Arc Discharge of High Voltage and Low Intensity 3.8

Basic Properties	3.1
Linear Expansion	3.2
Load Tables	3.3
Thermal Properties	3.4
Sound Insulation Properties	3.5
Vapour Permeability	3.6
Fire Protection Properties	3.7
Board Resistance against Arc Discharge of High Voltage and Low Intensity	3.8

# 3 Basic Properties of CETRIS® Cement Bonded Particleboard

## 3.1 Basic Properties

TABLE OF BASIC PHYSICAL AND MECHANICAL PROPERTIES OF CETRIS® CEMENT BONDED PARTICLEBOARD	STANDARD VALUES	MEAN VALUES ACTUALLY ACHIEVED
Bulk density pursuant to EN 323	min. 1,000 kg/m <sup>3</sup>	1,350 kg/m <sup>3</sup>
Tensile bending strength pursuant to EN 310	min. 9.0 N/mm <sup>2</sup>	min. 11.5 N/mm <sup>2</sup>
Elasticity module pursuant to EN 310	min. 4,500 N/mm <sup>2</sup>	min. 6,800 N/mm <sup>2</sup>
Tensile strength applied perpendicularly to the board plane pursuant to EN 319	min. 0.5 N/mm <sup>2</sup>	min. 0.63 N/mm <sup>2</sup>
Mass balanced moisture at 20° C and relative humidity 50 % pursuant to EN 634-1	9 ± 3 %	9.5 %
Linear expansion by air humidity change from 35 to 85 % at 23° C pursuant to EN 13 009		max. 0.122 %
Thermal expansion coefficient pursuant to EN 13 471		10 × 10 <sup>-6</sup> K <sup>-1</sup>
Board absorption rate after immersion into water for 24 hours		max. 16 %
Thickness swelling after immersion into water for 24 hours	max. 1.5 %	max. 0.28 %
Thermal conductivity coefficient pursuant to EN 12 664		th. 8 mm – 0.200 W/mK th. 22 mm – 0.251 W/mK th. 40 mm – 0.287 W/mK
Airbone sound transmission loss pursuant to ČSN 73 0513		th. 8 mm – 30 dB th. 24 mm – 33 dB th. 40 mm – 35 dB
Diffusion resistance factor pursuant to EN ISO 12 572		th. 8 mm – 52.8 th. 40 mm – 69.2
Weight activity Ra <sup>226</sup>	150 Bq/kg	22 Bq/kg
Weight activity index	I = 0.5	I = 0.21
Tensile strength after cycling in humid environment pursuant to EN 321	min. 0.3 N/mm <sup>2</sup>	min. 0.41 N/mm <sup>2</sup>
Thickness swelling after cycling in humid environment pursuant to EN 321	max. 1.5 %	max. 0.31 %
Frost resistance in 100 cycle test pursuant to EN 1328	R <sub>L</sub> > 0.7	R <sub>L</sub> = 0.97
Surface resistance to water and chemical defrosting agents (ČSN 73 1326)	Waste after 100 cycles max. 800 g/m <sup>2</sup> (method A)	Waste after 100 cycles max. 20.4 g/m <sup>2</sup> (method A)
	Waste after 75 cycles max. 800 g/m <sup>2</sup> (method C)	Waste after 75 cycles max. 47.8 g/m <sup>2</sup> (method C)
Resistance to arc discharge of high voltage and low intensity pursuant to EN 61 621		th. 10 mm – min. 143 sec
Board pH value		12.5
Sliding friction coefficient ČSN 74 4507		static μ <sub>s</sub> = 0,73 dynamic μ <sub>d</sub> = 0,76

TABLE OF BASIC FIRE RESISTANCE PROPERTIES	ACHIEVED VALUE
Reaction to fire pursuant to EN 13 501-1	A2-s1,d0
Surface spread of flame index pursuant to ČSN 73 0863	I = 0 mm/min

## 3.2 Linear Expansion

One of the properties of products containing wood-en mass is linear expansion and shrinkage caused by air humidity changes. This also applies to CETRIS® boards and must be taken into account by allowing the boards to sufficiently dilate. In the case of vertical cladding constructions a dilation of 4 – 5 mm is provided every 1,250 mm, or a dilation of 12 mm every 3,350 mm.

In the case of horizontal load-bearing constructions (such as floors), CETRIS® boards are set butted and the dilation joints are created along the walls in the minimum thickness of 15 mm. Size changes do not affect the quality or durability of CETRIS® boards.

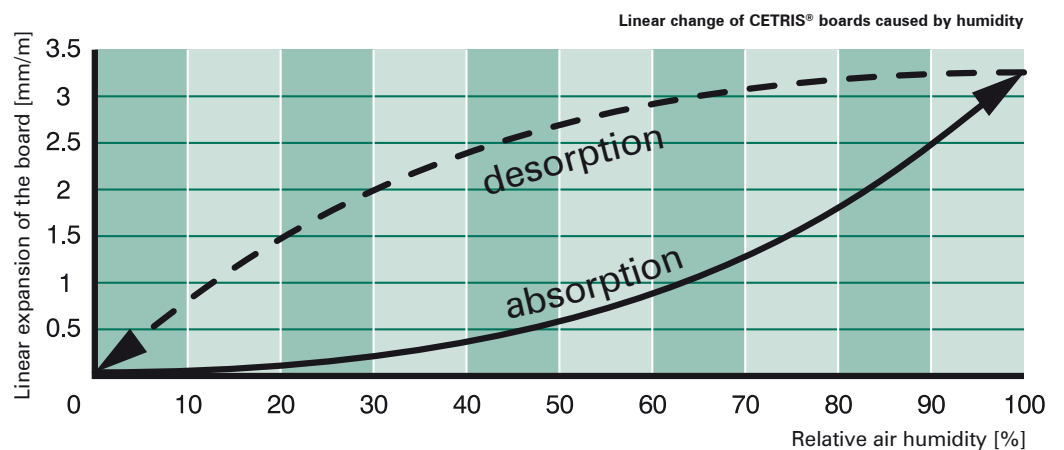

## 3.3 Load Tables

Structural analysis of the load-bearing capacity of CETRIS® boards has been made for board laying on beams (with the boards acting as a continuous beam). Joint action of the individual CETRIS® boards in the case of beams with two or more fields is assured by groove and tongue joint gluing, or edge gluing in the case of smaller board thicknesses.

The calculation was made for flexibly behaving material and with respect for the following mechanical and physical properties:

- Tensile bending strength min. 9 Nmm<sup>-2</sup>
- Elasticity module min. 4,500 Nmm<sup>-2</sup>
- Bulk density 1,400 kg/m<sup>3</sup>

When the load-bearing capacity was calculated, the effect of the boards own weight was also taken into account. The maximum normal strain in the marginal fibres under load does not exceed 3.60 Nmm<sup>-2</sup> (this means 2.5 multiple safety). Maximum deflection sag by traffic load including the boards own weight does not exceed 1/300 of the span. →

### Load Table for CETRIS® – concentrated load – 1 field beam

(applies for example for specification of thickness of a board – ceiling panel loaded with a solitary burden)

Beam span l (mm)	Maximum load F (kN)											
	th. 10	th. 12	th. 14	th. 16	th. 18	th. 20	th. 22	th. 24	th. 26	th. 28	th. 30	th. 32
200	0.298	0.431	0.587	0.767	0.972	1.201	1.454	1.731	2.032	2.357	2.707	3.080
250	0.291	0.420	0.573	0.750	0.951	1.175	1.423	1.694	1.990	2.309	2.651	3.018
300	0.250	0.410	0.559	0.732	0.929	1.148	1.391	1.657	1.946	2.259	2.595	2.954
350	0.205	0.361	0.545	0.714	0.906	1.121	1.359	1.619	1.903	2.209	2.538	2.889
400	0.170	0.302	0.489	0.695	0.883	1.093	1.326	1.581	1.858	2.157	2.479	2.824
450	0.141	0.255	0.417	0.632	0.860	1.065	1.292	1.541	1.812	2.105	2.420	2.757
500	0.117	0.216	0.357	0.546	0.789	1.036	1.258	1.501	1.766	2.053	2.360	2.690
550	0.097	0.183	0.307	0.473	0.688	0.958	1.223	1.461	1.719	1.999	2.300	2.622
600	0.078	0.154	0.263	0.410	0.601	0.842	1.137	1.420	1.672	1.945	2.239	2.553
650	0.062	0.128	0.225	0.356	0.526	0.741	1.006	1.325	1.624	1.891	2.177	2.483
700	0.047	0.105	0.191	0.308	0.461	0.654	0.892	1.179	1.520	1.836	2.115	2.414
750	0.033	0.084	0.160	0.265	0.402	0.576	0.790	1.050	1.359	1.720	2.052	2.343
800	0.020	0.065	0.132	0.226	0.349	0.506	0.700	0.935	1.216	1.544	1.925	2.273
850	0.007	0.047	0.106	0.190	0.301	0.443	0.619	0.832	1.087	1.387	1.734	2.132
900		0.030	0.082	0.157	0.257	0.385	0.545	0.739	0.971	1.245	1.562	1.926
950		0.014	0.060	0.127	0.217	0.333	0.478	0.654	0.866	1.116	1.406	1.739
1000			0.039	0.098	0.179	0.284	0.416	0.577	0.770	0.998	1.264	1.570
1050			0.020	0.072	0.144	0.239	0.358	0.505	0.682	0.890	1.134	1.415
1100			0.001	0.047	0.112	0.197	0.306	0.439	0.600	0.791	1.014	1.272
1150				0.024	0.082	0.158	0.256	0.378	0.525	0.700	0.904	1.141
1200				0.003	0.053	0.122	0.211	0.321	0.455	0.615	0.802	1.000

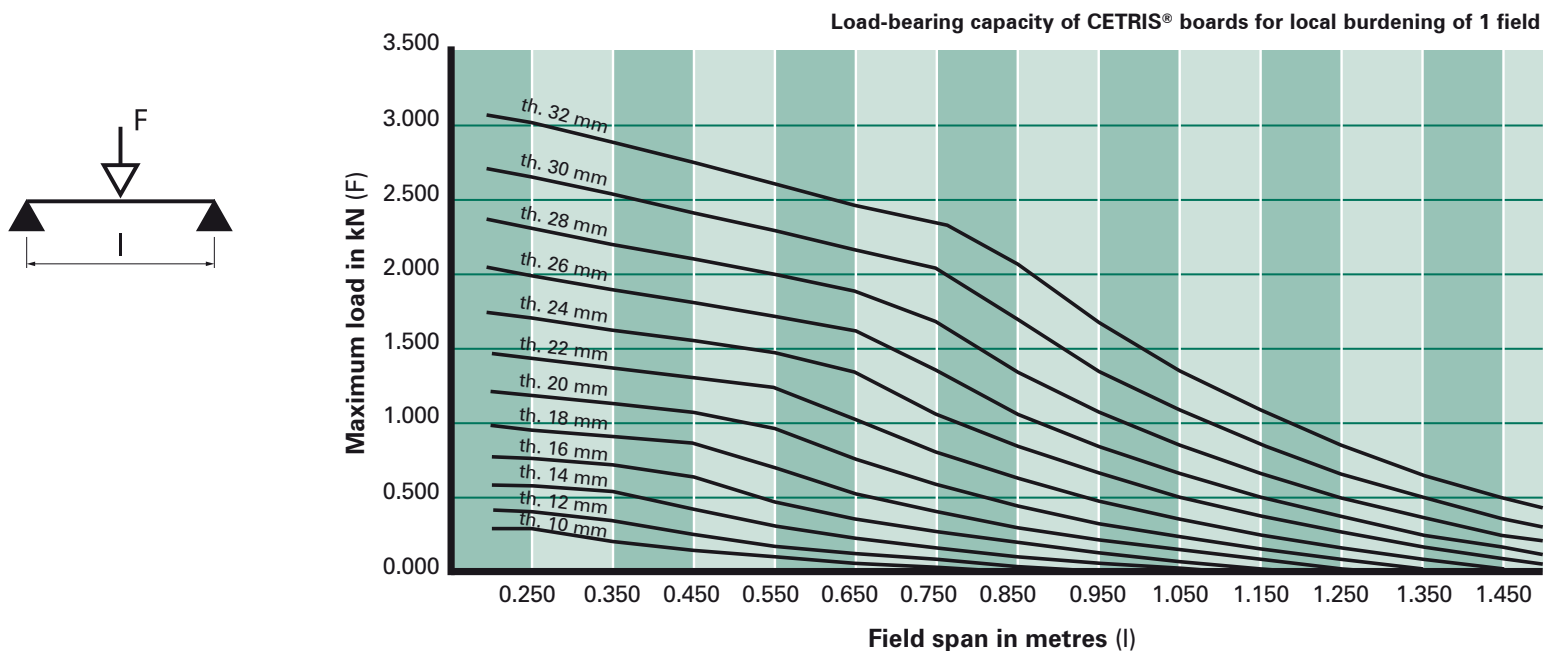

# 3 Basic Properties of CETRIS® Cement Bonded Particleboard

The calculation has verified that concentrated load is decisive for the CETRIS® board load-bearing capacity. The following tables and diagrams consider loading of the surface of 50 by 50 mm in the middle

of a board of min. width of 1 m (pursuant to EN). The static calculation further assumes that the forces act directly on the board surface.

The below data cannot be used for floor construction designing. For model designs of CETRIS® board floors and their load tables see Chapter 7 CETRIS® Floor Systems.

## Load Table for CETRIS® – line load – 1 field beam

(applies for example for specification of thickness of a board loaded with a line burden)

Beam span l (mm)	Maximum load F (kN/m)											
	th. 10	th. 12	th. 14	th. 16	th. 18	th. 20	th. 22	th. 24	th. 26	th. 28	th. 30	th. 32
200	1.186	1.711	2.332	3.050	3.863	4.772	5.777	6.878	8.076	9.369	10.758	12.243
250	0.938	1.361	1.857	2.430	3.079	3.805	4.608	5.488	6.444	7.477	8.588	9.774
300	0.640	1.121	1.539	2.014	2.554	3.158	3.826	4.558	5.353	6.213	7.137	8.125
350	0.459	0.810	1.301	1.716	2.178	2.694	3.265	3.891	4.572	5.307	6.098	6.943
400	0.340	0.606	0.980	1.480	1.894	2.344	2.842	3.389	3.983	4.626	5.316	6.054
450	0.257	0.456	0.758	1.151	1.657	2.070	2.512	2.996	3.523	4.093	4.706	5.361
500	0.196	0.362	0.597	0.913	1.321	1.833	2.246	2.681	3.154	3.665	4.215	4.803
550	0.150	0.285	0.477	0.735	1.070	1.491	2.006	2.421	2.850	3.313	3.812	4.345
600	0.114	0.225	0.384	0.599	0.878	1.228	1.659	2.178	2.595	3.018	3.474	3.962
650	0.085	0.177	0.310	0.491	0.726	1.022	1.387	1.827	2.348	2.767	3.187	3.635
700	0.061	0.138	0.250	0.404	0.604	0.857	1.169	1.546	1.993	2.517	2.939	3.354
750	0.041	0.106	0.201	0.332	0.504	0.722	0.991	1.317	1.704	2.158	2.683	3.109
800	0.024	0.078	0.159	0.272	0.421	0.610	0.844	1.128	1.466	1.862	2.321	2.848
850	0.009	0.054	0.124	0.221	0.350	0.516	0.721	0.970	1.266	1.615	2.019	2.483
900		0.034	0.093	0.177	0.290	0.435	0.615	0.835	1.097	1.406	1.764	2.175
950		0.015	0.066	0.139	0.238	0.366	0.525	0.720	0.952	1.227	1.546	1.912
1,000			0.042	0.106	0.192	0.305	0.444	0.619	0.827	1.072	1.358	1.686
1,050			0.021	0.076	0.152	0.252	0.377	0.532	0.718	0.937	1.194	1.489
1,100			0.001	0.049	0.116	0.204	0.316	0.454	0.621	0.819	1.050	1.317
1,150				0.025	0.083	0.162	0.262	0.386	0.536	0.714	0.923	1.165
1,200				0.003	0.054	0.123	0.213	0.324	0.459	0.621	0.810	1.029

Load-bearing capacity of CETRIS® boards for line burdening of 1 field

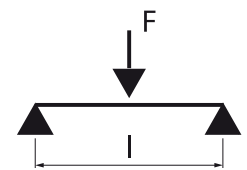
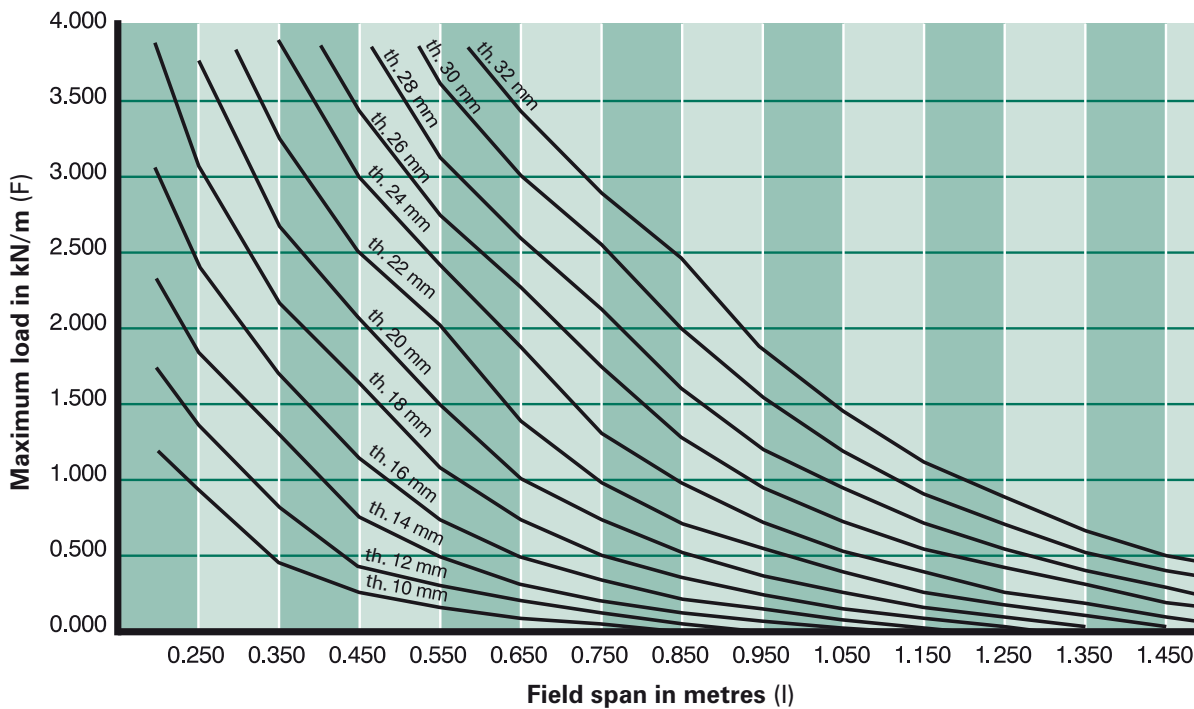

### Load Table for CETRIS® – continuous load – 1 field beam

(applies for example for specification of thickness of a board used as permanent formwork)

Beam span l (mm)	Maximum load q (kN/m <sup>2</sup> )											
	th. 10	th. 12	th. 14	th. 16	th. 18	th. 20	th. 22	th. 24	th. 26	th. 28	th. 30	th. 32
200	11.860	17.112	32.324	30.496	38.628							
250	6.004	10.449	14.857	19.437	24.631	30.440						
300	3.416	5.976	9.560	13.429	17.028	21.053	25.505	30.384				
350	2.099	3.701	5.948	8.947	12.444	15.393	18.657	22.234	26.124	30.328		
400	1.360	2.424	3.920	5.920	8.496	11.720	14.212	16.944	19.916	23.128	26.580	30.272
450	0.913	1.653	2.695	4.091	5.892	8.148	10.910	13.317	15.660	18.192	20.913	23.825
500	0.628	1.159	1.911	2.922	4.227	5.864	7.870	10.281	12.615	14.661	16.860	19.213
550	0.437	0.829	1.387	2.139	3.113	4.336	5.836	7.641	9.778	12.048	13.861	15.801
600	0.304	0.600	1.024	1.596	2.340	3.276	4.424	5.808	7.448	9.364	11.580	13.205
650	0.210	0.436	0.763	1.208	1.787	2.517	3.414	4.496	5.780	7.282	9.018	11.007
700	0.140	0.316	0.572	0.922	1.380	1.959	2.672	3.533	4.555	5.752	7.137	8.723
750	0.088	0.225	0.428	0.708	1.075	1.540	2.115	2.810	3.636	4.603	5.724	7.009
800	0.048	0.156	0.319	0.544	0.842	1.220	1.689	2.256	2.932	3.724	4.643	5.696
850	0.016	0.102	0.233	0.416	0.660	0.971	1.356	1.825	2.383	3.040	3.801	4.674
900		0.060	0.165	0.315	0.516	0.773	1.094	1.484	1.951	2.499	3.136	3.867
950		0.025	0.111	0.235	0.401	0.616	0.884	1.212	1.604	2.066	2.603	3.221
1,000			0.067	0.169	0.308	0.488	0.714	0.991	1.323	1.715	2.172	2.698
1,050			0.032	0.116	0.232	0.383	0.575	0.810	1.094	1.428	1.819	2.269
1,100			0.002	0.071	0.169	0.297	0.460	0.661	0.904	1.191	1.527	1.915
1,150				0.035	0.116	0.225	0.364	0.537	0.745	0.994	1.284	1.620
1,200				0.004	0.072	0.164	0.284	0.432	0.612	0.828	1.080	1.372

Load-bearing capacity of CETRIS® boards for continuous burdening of 1 field

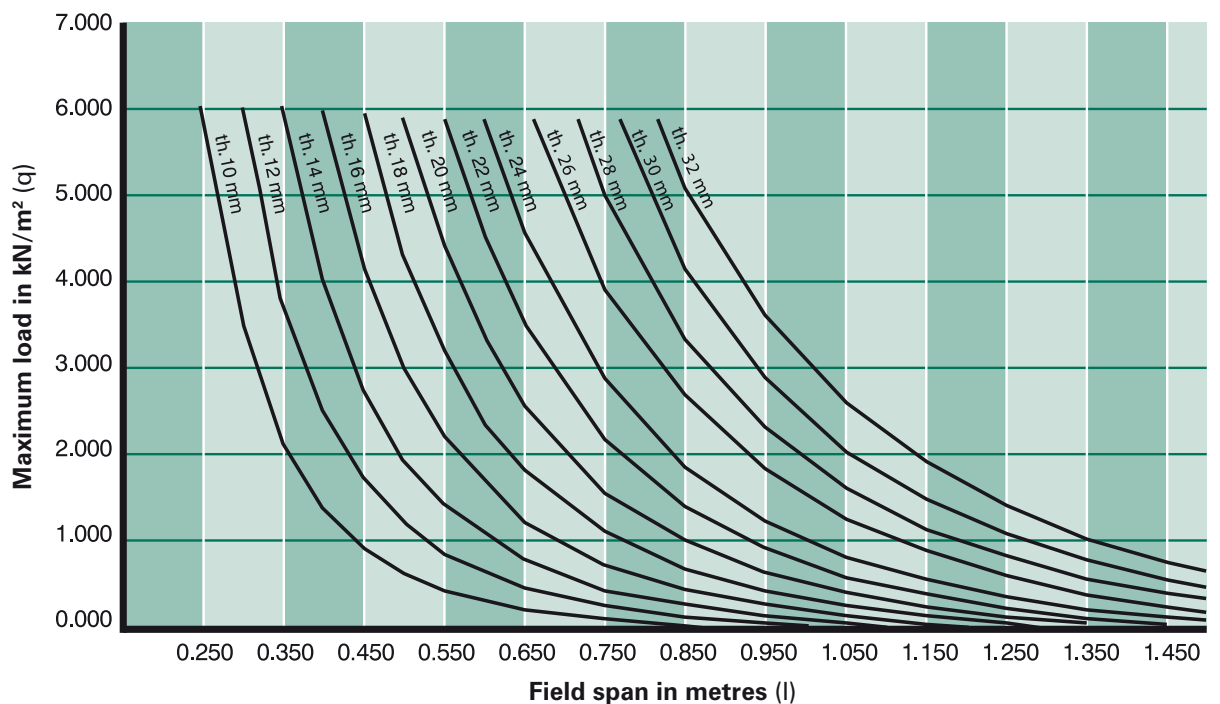
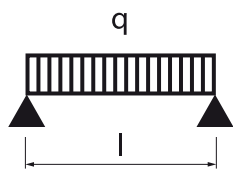

# 3 Basic Properties of CETRIS® Cement Bonded Particleboard

## 3.4 Thermal Properties

The heat conductivity or the heat conductivity coefficient represents the most important indicator of building materials with regard to thermal performance. The CETRIS® cement bonded particleboard, thanks to its ideal connection of wood and cement, is

a good heat conductor. For that reason their application area includes all applications requiring compact materials with the lowest thermal resistance possible to minimise heat loss. This is for example the case of floor heating applications. Floor heating is dealt with in more detail in a separate chapter, 7.10 Floor Heating.

Heat conductivity of CETRIS® boards in relation to thickness:

CETRIS® BOARD THICKNESS (mm)	HEAT CONDUCTIVITY $\lambda$ (W/mK)	THERMAL RESISTANCE R (m <sup>2</sup> K/W)
8	0.200	0.040
24	0.251	0.096
40	0.287	0.139

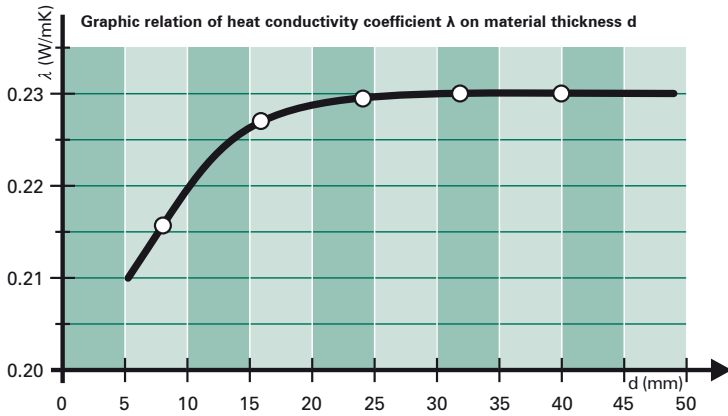

$\lambda = \text{max. } 0.287 \text{ W/mK}$   
(for mass humidity  $9 \pm 3 \%$ )

Higher humidity causes proportional increase of heat conductivity which should not exceed 0.35 W/mK.

The above values of heat conductivity are measured in dry conditions. The effect of moisture on heat conductivity is not negligible, though. Higher humidity causes a proportional increase of heat conductivity. That is why the heat conductivity values should be related to a stabilised CETRIS® board moisture level.

## 3.5 Sound Insulation Properties

On the basis of evaluation of tests of acoustic properties by the Construction Research Institute in Prague the acoustic properties of CETRIS® boards are excellent and therefore the boards are ideal for cladding of light partitions, walls and ceilings and may also be used as sound absorbing ceiling panels. CETRIS® cement bonded particleboards show low sound absorption, therefore are classified as reflexive sound barriers.

For increased sound absorption it is recommended to use CETRIS® boards with sound absorbing material.

Following values have been tested for the purpose of application of the boards in sound protection systems:

Sound transmission loss coefficient	0.013
Lengthwise wave spread rate	2,128 m/s
Material constant	22.7
Index $R_w$ :	
th. 8, 10 mm	30 dB
th. 12, 14 mm	31 dB
th. 16, 20 mm	32 dB
th. 24 mm	33 dB
th. 32 mm	34 dB
th. 40 mm	35 dB

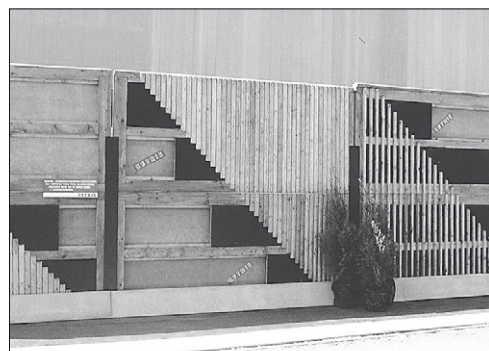

### Sound transmission loss of wall constructions clad with CETRIS® cement bonded particleboard

One of the possibilities to reduce noise transmission from the source to the recipient is an effective noise barrier. The ability of building structures to transfer and reduce acoustic output spreading through the air is provided by acoustic materials (insulation etc.). Sound transmission loss is a feature of building construction to provide noise insulation of two neighbouring rooms and protect the rooms from airborne noise. The basic rule is: the higher the sound transmission loss the better!

**Weighed laboratory sound transmission loss  $R_w$  (dB)** of selected wall constructions clad with CETRIS® cement bonded particleboard was measured in laboratory on specimen of prescribed size pursuant to EN ISO 140-3 Acoustics – Measurements of noise barriers represented by building constructions and noise barriers in buildings – Part 3: Laboratory measurements of sound transmission loss in building constructions. For the other structures of walls and partitions the values of sound transmission loss are shown in the table on page 134 (chapter CETRIS® Board Application in Fire Protection, Survey of Fire Walls) and specified by calculation.

**Weighed construction sound transmission loss  $R'w$  (dB)** – is STL measured in a particular building structure on site. For the reason of different conditions of measurement (effects bypasses) the results on site are always worse than in the laboratory. The following equation applies to building sound transmission loss  $R'w$  (dB):

$$R'w = R_w - k \text{ (dB)}$$

Where “k” is the correction depending on the bypass direction of air flow (usually  $k = 2 - 3$  dB, in the case of composite constructions the value is recommended to be specified individually on the basis of knowledge of the surroundings and the bypass direction).

### Informative compositions – requirements for noise insulation between rooms in buildings pursuant to ČSN 73 0532 Acoustics – Assessment of noise insulation of building constructions and in buildings

SPACE	REQUIREMENTS FOR NOISE ABSORPTION BY PARTITIONS $R'w$	PROPOSED COMPOSITION
<b>Residential houses – one living room in a multi-room apartment</b>		
All other rooms of the same apartment unless functional parts of the protected space	42 dB	CETRIS® 12 mm, CW profile 75 + 60 mm mineral wool, CETRIS® 12 mm
<b>Residential houses – apartment</b>		
All rooms of other apartments	52 dB	CETRIS® 2 × 12 mm, CW profile 75 + 60 mm mineral wool, CETRIS® 2 × 12 mm
Common spaces (staircases, corridors etc.)	52 dB	CETRIS® 2 × 12 mm, CW profile 75 + 60 mm mineral wool, CETRIS® 2 × 12 mm
Common unused spaces (such as lofts)	47 dB	CETRIS® 12 mm, CW profile 75 + 60 mm mineral wool, CETRIS® 12 mm
Passages, subways	52 dB	CETRIS® 2 × 12 mm, CW profile 75 + 60 mm mineral wool, CETRIS® 2 × 12 mm
<b>Hotels and accommodation facilities – bedroom space, guest rooms</b>		
Rooms of other guests	47 dB	CETRIS® 12 mm, CW profile 75 + 60 mm mineral wool, CETRIS® 12 mm
Common spaces (staircases, corridors etc.)	47 dB	CETRIS® 12 mm, CW profile 75 + 60 mm mineral wool, CETRIS® 12 mm
<b>Hospitals, sanatoria – wards, doctors' offices</b>		
Wards, surgeries	47 dB	CETRIS® 12 mm, CW profile 75 + 60 mm mineral wool, CETRIS® 12 mm
auxiliary spaces	47 dB	CETRIS® 12 mm, CW profile 75 + 60 mm mineral wool, CETRIS® 12 mm
<b>Schools and educational institutions</b>		
Classrooms	47 dB	CETRIS® 12 mm, CW profile 75 + 60 mm mineral wool, CETRIS® 12 mm
Common spaces	42 dB	CETRIS® 12 mm, CW profile 75 + 60 mm mineral wool, CETRIS® 12 mm
Noisy rooms (gyms, workshops, dining halls) $L_a$ max. <85 dB	52 dB	CETRIS® 2 × 12 mm, CW profile 75 + 60 mm mineral wool, CETRIS® 2 × 12 mm
<b>Offices and studies</b>		
Offices and studies	37 dB	CETRIS® 12 mm, CW profile 75 + 60 mm mineral wool, CETRIS® 12 mm
Studies with increased demand for noise protection	47 dB	CETRIS® 12 mm, CW profile 75 + 60 mm mineral wool, CETRIS® 12 mm

# 3 Basic Properties of CETRIS® Cement Bonded Particleboard

## Laboratory measurements of sound transmission loss pursuant to EN ISO 140-3

### Wall 1

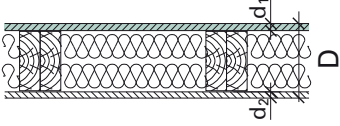

#### Composition:

- CETRIS® board 14 mm
- Wooden frame 120 mm
- ORSIL Uni 2 × 60 mm
- Plasterboard KNAUF GKB thickness 12.5 mm

Assessment pursuant to EN ISO 717-1

$$R_w (C; C_{tr}) = 46 (-2; -6) \text{ dB}$$

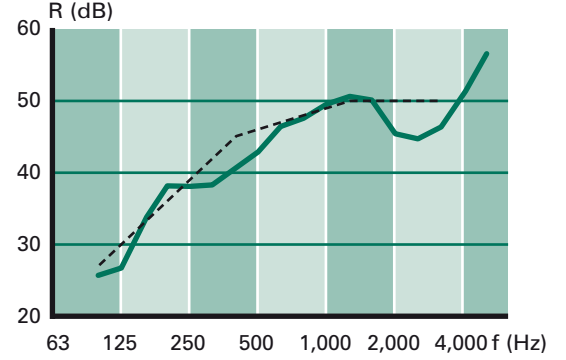

FREQUENCY	Hz	100	125	160	200	250	315	400	500	630	800	1,000	1,250	1,600	2,000	2,500	3,150	4,000	5,000
R 1/3 oct	dB	25.6	26.7	33.2	38.1	38.0	38.2	40.8	42.9	46.5	47.6	49.5	50.6	50.1	45.5	44.7	46.4	51.1	56.6

### Wall 2

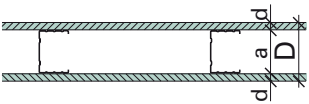

#### Composition:

- CETRIS® board 12 mm
- CW profile 75 mm
- CETRIS® board 12 mm

Assessment pursuant to EN ISO 717-1

$$R_w (C; C_{tr}) = 43 (-2; -5) \text{ dB}$$

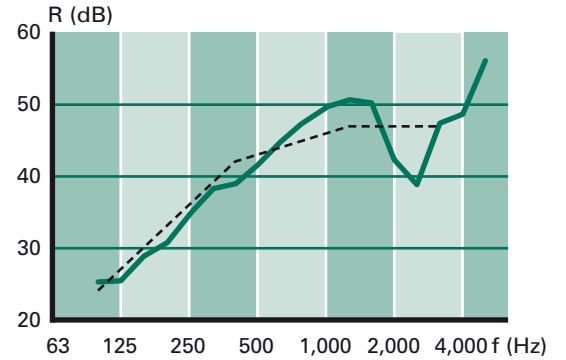

FREQUENCY	Hz	100	125	160	200	250	315	400	500	630	800	1,000	1,250	1,600	2,000	2,500	3,150	4,000	5,000
R 1/3 oct	dB	25.2	25.4	28.8	30.7	34.8	38.3	38.9	41.7	45.0	47.7	49.7	50.7	50.3	42.3	38.7	47.5	48.6	56.2

### Wall 3

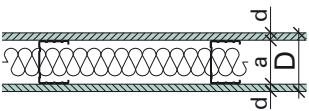

#### Composition:

- CETRIS® board 12 mm
- CW profile 75 mm
- ORSIL Hardsil 60 mm
- CETRIS® board 12 mm

Assessment pursuant to EN ISO 717-1

$$R_w (C; C_{tr}) = 52 (-2; -5) \text{ dB}$$

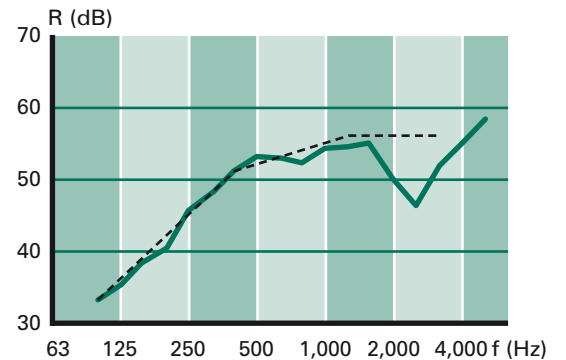

FREQUENCY	Hz	100	125	160	200	250	315	400	500	630	800	1,000	1,250	1,600	2,000	2,500	3,150	4,000	5,000
R 1/3 oct	dB	33.2	35.3	38.5	40.3	45.7	48.0	51.2	53.2	53.0	52.3	54.3	54.5	55.1	50.2	46.2	51.8	55.1	58.4



### Wall 4

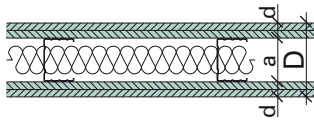

#### Composition:

- 2 CETRIS® boards 12 mm
- CW profile 75 mm
- ORSIL Hardsil 60 mm
- 2 CETRIS® boards 12 mm

Assessment pursuant to EN ISO 717-1  
 $R_w (C; C_{tr}) = 56 (-1; -3) \text{ dB}$

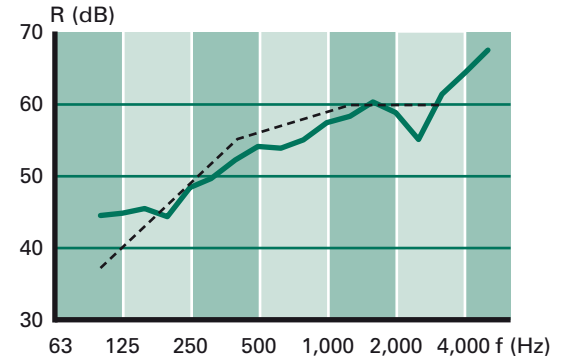

FREQUENCY	Hz	100	125	160	200	250	315	400	500	630	800	1,000	1,250	1,600	2,000	2,500	3,150	4,000	5,000
R 1/3 oct	dB	44.5	44.8	45.5	44.3	48.4	49.8	52.4	54.2	54.0	55.2	57.5	58.4	60.4	59.0	55.2	61.4	64.4	67.6

Note: Board measurements were performed by Centrum stavebního inženýrství, a.s., Prague, Zlín office, in October 2006 under the following conditions:  
Test sample surface area 10.3 m<sup>2</sup>, transmission chamber volume 90.3 m<sup>3</sup>, receiving chamber volume 70 m<sup>3</sup>, temperature 18 – 19° C, relative humidity 44 – 47%

## 3.6 Vapour Permeability

Diffusion is the ability of molecules of gas, vapour or liquid to permeate through molecules of a porous material. When the porous material separates two spaces with a difference between partial pressures of vapour, vapour diffusion occurs. Vapour diffuses from the space where the partial vapour pressure is higher in macro-capillaries with the diameter  $d > 10^{-7} \text{ m}$ , because no capillary condensation happens in these capillaries.

Diffusion (diffusion resistance factor) is measured pursuant to *EN ISO 12572 Thermal behaviour of construction materials and products in relation to humidity – Specification of vapour permeation*.

Diffusion is tested on an exactly defined sample tightly closing the space of the test bowl containing either a drying agent (Silicagel) or a saturated solution (wet bowl). The set is placed in a test chamber with controlled temperature and air humidity. For the reason of different partial vapour pressure between the space of the test bowl and the chamber, vapour begins to flow through the permeable samples. Regular weighing of the set serves for specification of vapour permeation in the stable condition.

Ability of building materials to let vapour pass through by diffusion can be expressed by:

- Diffusion conductivity coefficient (vapour diffusion)  $\delta$
- Diffusion resistance factor  $\mu$
- Equivalent diffusion thickness  $s_d$

There are exactly defined relations between these values.

**Diffusion conductivity coefficient (vapour diffusion)  $\delta$  (s)** is product of vapour permeability and thickness of a homogeneous sample. The coefficient was specified for CETRIS® cement bonded particleboard in 1991 (pursuant to ČSN 72 7031, tested thickness 12 mm) with the resulting value of  $0.00239 \times 10^{-9} \text{ s}$ , or  $8.604 \times 10^{-6} \text{ g/mhPa}$ .

**The value of diffusion resistance factor  $\mu$  (dimensionless) is used more often.** It is the quotient of diffusion conductivity coefficient of vapour and building material. The factor expresses how many times higher the diffusion resistance of the building material is in comparison to a layer of air of the same thickness and temperature. Therefore the higher the value of the resistance the less permeable

the material (the value achieved by mineral wool is 1 – 2, polystyrene and concrete values are 120 – 150, hydro insulation values equal to thousands). The diffusion resistance factor was specified by testing pursuant to EN ISO 12 572 for CETRIS® boards with the following results:

- For thickness 8 mm (the thinnest)  $\mu = 52.8$
- For thickness 40 mm (the thickest)  $\mu = 69.2$

**Equivalent diffusion thickness  $s_d$  (m)** – thickness of the equivalent air gap is the thickness of a layer of calm air with the same diffusion resistance as the test sample.

For CETRIS® cement bonded particleboards the equivalent diffusion thickness generally equals to  $s_d = \mu \times d$ , where  $d$  is the material thickness, i.e.:

- For thickness 8 mm (the thinnest)  
 $s_d = 52.8 \times 0.008 = 0.43 \text{ m}$
- For thickness 40 mm (the thickest)  
 $s_d = 69.2 \times 0.040 = 2.78 \text{ m}$
- for other thicknesses (generally)  
 $s_d = \mu \times d$

*d ..... thickness of the CETRIS® board in m  
 $\mu$  ..... interpolated value from the table  
(for thickness range 10 – 38 mm)*

	THICKNESS OF CETRIS® BOARD (mm)																
	th. 8	th. 10	th. 12	th. 14	th. 16	th. 18	th. 20	th. 22	th. 24	th. 26	th. 28	th. 30	th. 32	th. 34	th. 36	th. 38	th. 40
$\mu$	52.8	53.7	54.6	55.5	56.4	57.3	58.2	59.1	60.0	60.9	61.8	62.7	63.6	65.0	66.4	67.8	69.2
$s_d$ (m)	0.43	0.54	0.66	0.78	0.90	1.03	1.16	1.30	1.44	1.58	1.73	1.88	2.04	2.21	2.39	2.58	2.78

## 3.7 Fire Protection Properties

### Classification of cement bonded particleboard by reaction to fire class pursuant to European standard

For the purpose of unified classification of building materials a new system has been introduced, completed and implemented as standard EN 13 501-1 Fire Classification of Building Products and Building Constructions – Part 1: Classification Based on Results of Tests of Reaction to Fire.

This new system eliminates, in the given area, the principal differences between the national systems of EU countries representing a serious obstacle to common trade. Another advantage of the system is the more accurate evaluation of building products. The new test standards are closer to the results of large dimension tests, i.e. behaviour in the care of actual fire.

### Classification of CETRIS® cement bonded particleboard based on its reaction to fire was performed on the basis of results of tests carried out pursuant to the following European standards:

- EN ISO 1182:2002 – Non-Flammability Test
- EN ISO 1716:2002 – Specification of Burning Heat
- EN 13823:2002 – Test by Single Burning Item (SBI)
- EN ISO 11925-2:2002 – Test of Ignitability by single Flame Source (Inflammability Test)

On the basis of these tests performed by the IBS – Institut für Brandschutztechnik und Sicherheitsforschung Linz (Austria), CETRIS® cement bonded particleboards are classified as **A2**. Its complementary classification of smoke generation is **s1**, its classification of flaming drops (particles) is **d0**,

which means the resulting classification of **A2-s1,d0**. This result applies to classification of the board behaviour in fire conditions, except for flooring.

The cement bonded particleboard is also classified pursuant to other national standards:

- Pursuant to **PN-B-02874:1996** (Protocol NP-595/02/JF, implemented) – **classification niezapalny** (non-flammable).

## 3.8 Board Resistance against Arc Discharge of High Voltage and Low Intensity

ELEKTROTECHNICKÝ ZKOUŠEBNÍ ÚSTAV Počet stran:2  
Pod Lisem 129 Počet příloh/Počet stran příloh:-/-  
171 02 Praha 71 Zn.,Lk/Ba

Číslo protokolu: 301508-01/01 Datum vydání: 12. 5. 2003



**PROTOKOL O ZKOUŠCE**

Výrobek: Cementofisková deska  
Typ: CETRIS  
Jmenovité hodnoty: tloušťka 10mm  
Výrobní číslo: -  
Výrobce: CIDEM Hranice, a.s., divize CETRIS, Skalná 1088, 753 40 Hranice I - Město, Česko  
Výrobní místo: CIDEM Hranice, a.s., divize CETRIS Skalná 1088, 753 40 Hranice I - Město, Česko  
Číselník výrobků EZÚ: 105001 - ostatní služby  
Objednavatel: CIDEM Hranice, a.s., divize CETRIS, Skalná 1088, 753 40 Hranice I - Město, Česko

Počet zkoušených vzorků: 10  
Vzorky předloženy dne: 7.4.2003  
Místo provedení zkoušek: Elektrotechnický zkušební ústav, s.p.  
Zkoušky prováděny v době od 28. 4. 2003 do 2. 5. 2003  
Jiné údaje:  
Výrobek zkoušen podle: ČSN EN 61 621:98

Zpracoval: M. Baron  
Pod Lisem 129  
171 02 Praha 71  
Ing. V. Lužvák  
171  
technický vedoucí  
zkoušební laboratoře 344

Všechny zkoušky uvedené v protokolu se kromě zkoušebního předmětu a jsou zvláště v přenesení podrobeny zkoušebním předpisem. Každá zkouška prováděná v EZÚ musí být provedena v souladu s předpisy, které jsou v platnosti v době zkoušení. Každá zkouška provedená v EZÚ jako akreditovaná laboratoře, musí používat formátů typu „zkoušení EZÚ, laboratoř akreditovaná ČIA v uvedeném zkoušení, seřazení čísel akreditované laboratoře 1000“.

Tel.: 266104111 Fax: 26680970 E-mail: testing@ezu.cz  
http://www.ezu.cz

### New application of CETRIS® cement bonded particleboard

CETRIS® cement bonded particleboard is a universal board material for interior and exterior use. It is distinguished from other board materials by its high resistance to weather effects, fire, mechanical damage and demanding technological space conditions. On the basis of requirements coming from electricity distribution companies, the cement bonded particleboard CETRIS® has been tested for resistance against arc discharge of high voltage and low intensity pursuant to EN 61 621:1998 (IEC 61621:1997).

The testing was performed in May 2003 in the Electro-technical Test Institute in Prague – Trója with the testing apparatus MICAFIL ART 68 with the following result for CETRIS® board, thickness 10 mm:

- Minimum time to conductive path 143 s
- Mean time to conductive path 180.25 s

CETRIS® cement bonded particleboard complies with its resistance to electrical arc in spaces with high voltage wiring (collectors).

**Justification:** The mean and the minimum value of the measured times to the conductive path is lower than the protection switch off times of distribution network HV and LV wiring.

Cutting	4.1
Drilling	4.2
Milling	4.3
Sanding	4.4

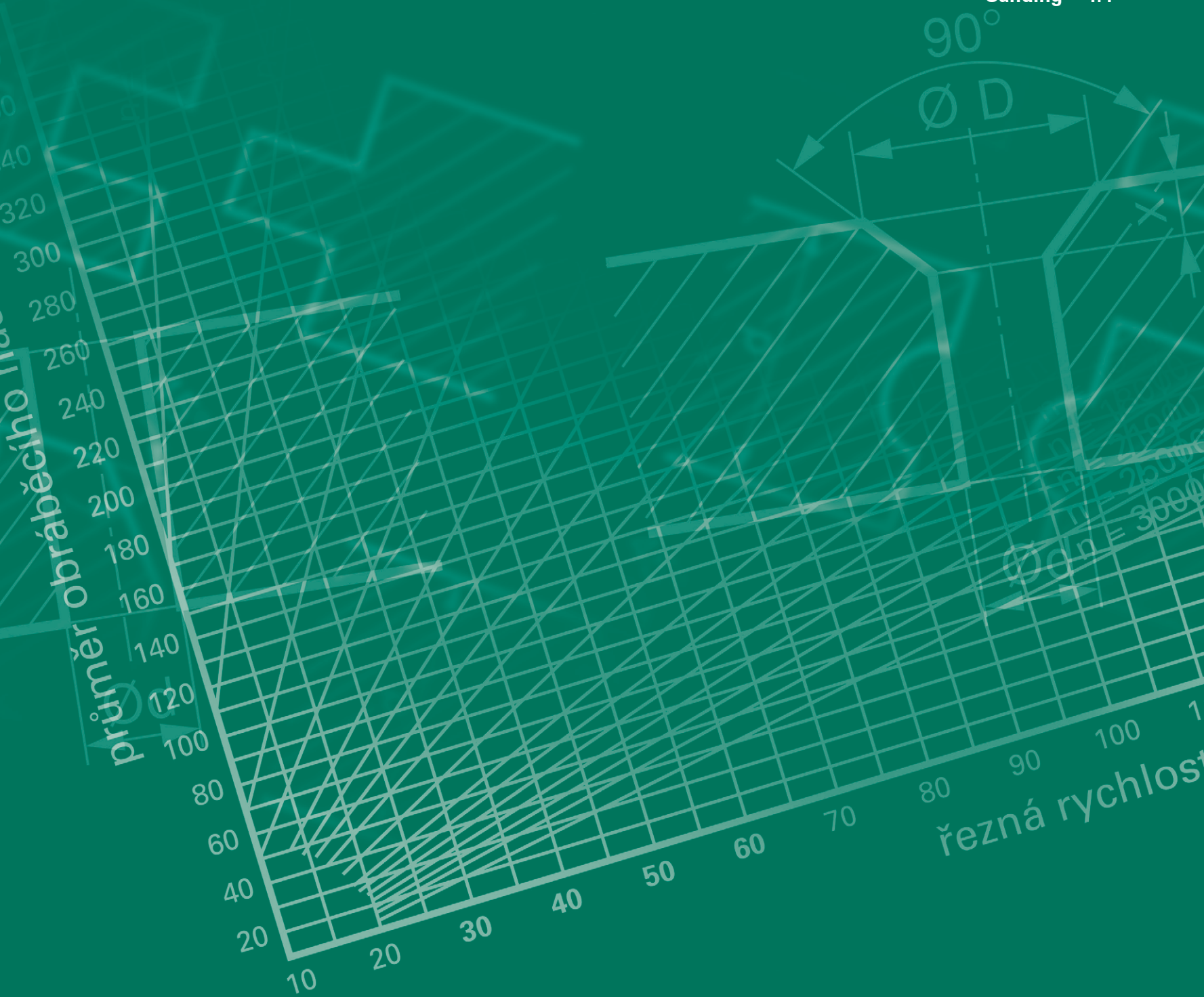

A great advantage of CETRIS® cement bonded particleboards is that they can be processed by all common wood processing machines. For professional processing of CETRIS® boards, only hard metal instruments should be used. CETRIS® boards can be cut, drilled, milled and ground.

## 4.1 Cutting

The boards can be cut in the manufacturing plant on the basis of customer requirements with a specialised device. If a customer wants to cut the boards with its own equipment it is recommended to use common hard metal wood cutting instruments (SK lamellas). To achieve the optimum cutting speed of 30 – 60 m/s it is recommended to use machines with electronic revolution control. Cutting of CETRIS® boards results in very fine dust waste.

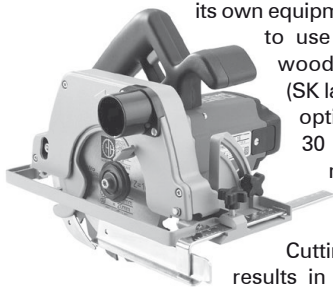

Surface finished boards (CETRIS® FINISH, and PROFIL FINISH) must be cut on the reverse (not treated) side to prevent damage to the front face with the surface finish. Even though the dust does not contain any harmful substances its exhausting is recommended for the reason of working environment protection.

Relation of progress of processing tool on cutting speed (n = tool revolutions)

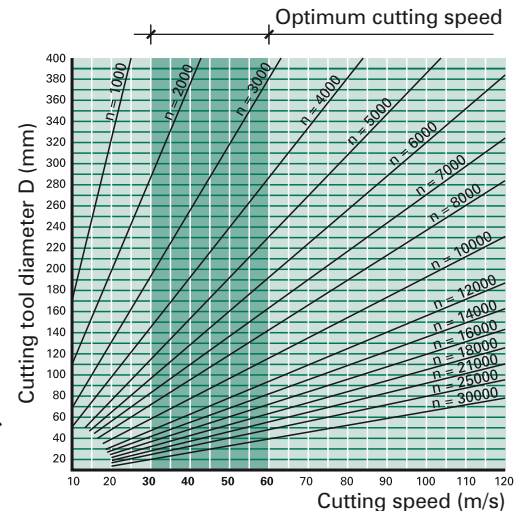

## 4.2 Drilling

On the basis of a customer submitted drilling plan, the boards may be drilled (including countersinking) directly in the manufacturing plant.

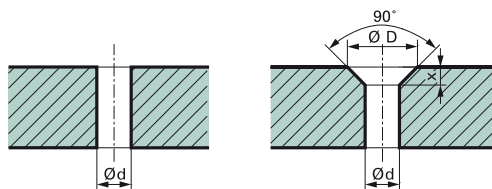

Drill bits for drilling metal may be used. In the case of manual drilling it is recommended to use electrical drills with electronic revolution control. Surface finished boards (CETRIS® FINISH and PROFIL FINISH) are drilled from the face side (with surface finish). Drilling from the reverse side might damage the face.



## 4.3 Milling

CETRIS® cement bonded particleboards can be milled if required by the customer (for example semi-tongue, tongue and groove, edge chamfering etc.). If the customer wants to use its own mills

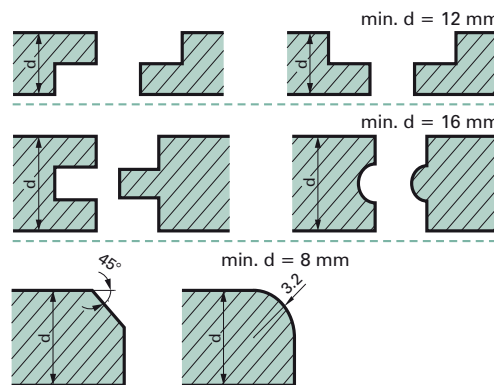

for milling the same principles as in the case of the previous processing methods apply. When milling, it is necessary to observe the mechanical properties of the boards (minimum thickness). The recommended cutting speed ranges within the interval 25 – 35 m/s.

## 4.4 Sanding

Full area machine sanding of CETRIS® cement bonded particleboards in the manufacturing plant is performed for the purpose of production of sanded flooring CETRIS® PDB for the reason of reduction of thickness tolerance to ±0.3 mm.

Manual sanding can be performed in the points of contact of the boards where uneven surface must be levelled or the board surface needs roughing. The instruments used include electrical manual sanders with abrasion paper of 40 – 80 granularity value. In this case exhausting of the resulting dust is also recommended.



Screwing 5.1

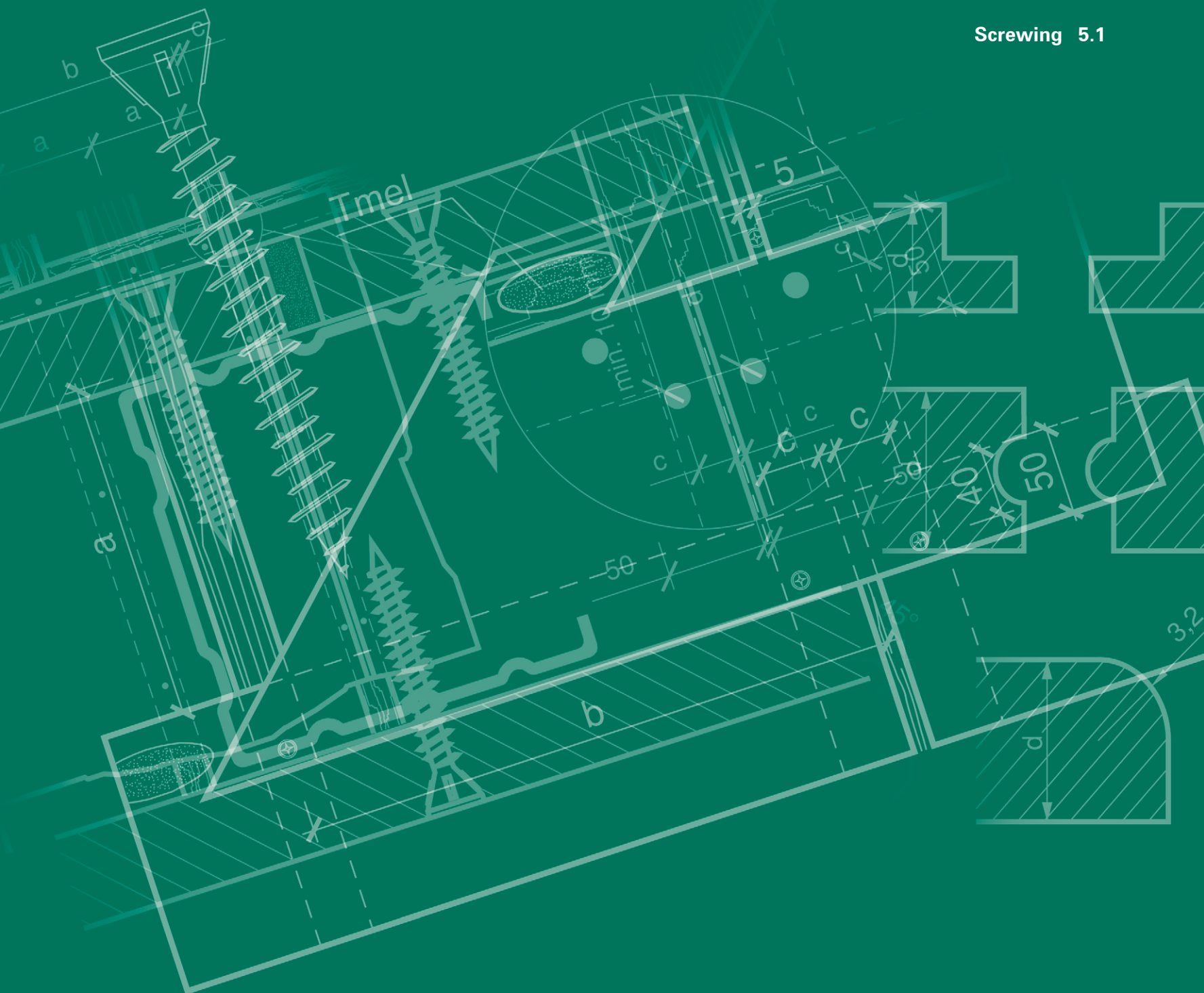

CETRIS® boards can be fastened to constructions by screwing or riveting. Use of nails and bolts used for plasterboard is not recommended. All types of fastening elements must be treated with an anti-corrosion agent. Alternatively CETRIS® boards may be fixed to the load-bearing construction by gluing or clamping. Both methods are mainly used for fixation of the boards in the system of suspended vented façades.

## 5.1 Screwing

### 5.1.1 Interior Anchoring

#### 5.1.1.1 Screwing to Timber

For correct fixation of CETRIS® boards to constructions it is necessary to observe the maximum spacing of the load-bearing construction and the fixation elements.

The best fastening element for fixation of CETRIS® boards is a self-cutting screw with double thread, hardened tip and sunken head with blades for countersinking. This type of screw may be supplied as an auxiliary material with CETRIS label, diameter 4.2 mm, lengths 35, 45, 55 mm for connecting of two CETRIS® boards in the floating floor system or for board fixation to horizontal and vertical timber constructions (floors, partitions, ceiling panels, etc.). For anchoring purposes the screw should penetrate to the wooden construction with at least 2/3 of its length. For fixation of floor boards, a screw of the length exceeding the board thickness by 20 mm will suffice.

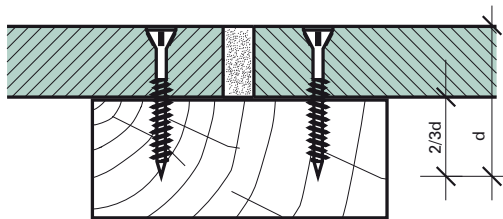

CETRIS self-cutting screw to timber



#### 5.1.1.2 Screwing to Sheet Metal

For fixation of CETRIS® boards to sheet metal profiles there is the self-cutting screw, CETRIS 4.2 × 25 mm (this screw is threaded up to the head), or screws 4.2 × 35, 45, 55 mm (thread up to about 2/3 of the shank length). The most often used load-bearing constructions include zinc-coated profiles CW and UW. Horizontal UW profiles are anchored via sound absorbing inserts to the ceiling (floor) construction. Vertical CW profiles are inserted in the UW profiles, about 15 mm shorter than the room height. The CETRIS® board for wall cladding is only fixed to the vertical profiles (stands – CW). When anchoring to sheet metal profiles the screw should protrude by at least 10 mm through the thickness of the board. It is recommended to pre-drill the CETRIS® board.

In the point of contact – of the vertical joint and the vertical CW profile – first anchor the CETRIS® board closer to the stand of the CW profile. In the case of the opposite procedure (anchoring to the soft part of the CW profile) there is the risk of deformation of the profile and subsequently the cladding too!

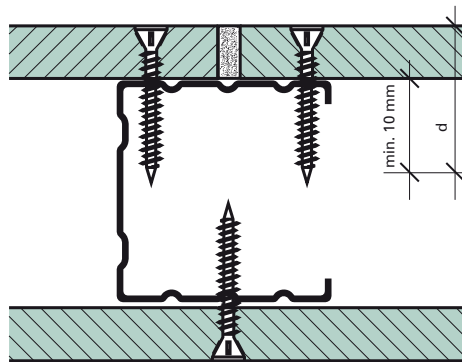

CETRIS self-cutting screw to sheet metal



When using regular screws the screw holes should be pre-drilled to 1.2 multiple of the screw used. It is also recommended to prepare the countersinking for the sunken screw heads. For professional screwing it is recommended to use pneumatic or electrical screwdrivers with regulated revolutions. This method also applies to exterior applications when the CETRIS® board is used as the base under a contact thermal insulation system and in the overlapping façade system PLANK.

### Resistance to the screw pulling out of CETRIS® cement bonded particleboard

#### A) Specification of resistance to the screw pulling out perpendicularly to the board plane:

Test method:  
EN 320

Screw type:  
CETRIS 4.2 × 35 mm  
(pre-drilled hole in the board with a diameter of 3.5 mm)

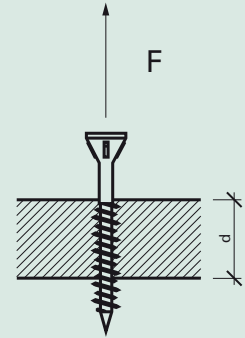

Board thickness d	Resistance
8 mm	597 N
10 mm	788 N
12 mm	1,305 N

#### B) Specification of resistance to the screw pulling out parallel to the board plane:

Test method:  
EN 320

Screw type:  
CETRIS 4.2 × 35 mm  
(pre-drilled hole in the board with a diameter of 3.5 mm)

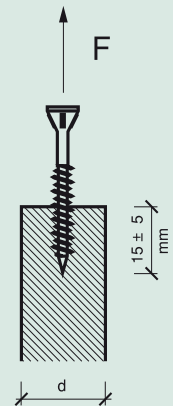

Board thickness d	Resistance
22 mm	1,039 N

Note: Informative values.

## 5.1.2 Exterior Anchoring

CETRIS® boards are fixed in the VARIO system (visible joints) with stainless or galvanized screws with semi-circular or hexagonal heads and compressive water-tight washers. These washers are treated on the bottom side with vulcanized elastomer EPDM

for water-tight and flexible material connection. The screw type also depends on the base type – the load-bearing grid applied. Rivets may be used for anchoring to zinc-coated (aluminium) constructions. The types of screws and rivets are described

in Chapter 8.7.7 Auxiliary Materials. In that chapter you will also find information about board gluing to the load-bearing construction with the SikaTack® Panel gluing system.

## 5.1.3 Support Span, Screw (Bolt) Spacing

### Interior wall – no fire resistance requirement

(or exterior cladding under contact thermal insulation systems)

BOARD THICKNESS (mm)	a (mm)	b (mm)	c <sub>1</sub> (mm)	c <sub>2</sub> (mm)
8	< 200	< 420	> 25 < 50	> 50 < 100
10	< 250	< 500		
12, 14	< 250	< 625		
16, 18, 20	< 300	< 670		
22, 24, 26, 28, 30	< 350	< 670		
32, 34, 36, 38, 40	< 400	< 670		

### Interior wall with fire resistance requirement (or exterior cladding under thermal insulation systems)

For details see Chapter 9.2

BOARD THICKNESS (mm)	a (mm)	b (mm)	c <sub>1</sub> (mm)	c <sub>2</sub> (mm)
10, 12, 14, 16, 18	< 200	< 625	> 25 < 50	> 50 < 100

### Interior + exterior ceiling panel with fire resistance requirement

For details see Chapter 9.3

BOARD THICKNESS (mm)	a (mm)	b (mm)	c <sub>1</sub> (mm)	c <sub>2</sub> (mm)
12	< 200	< 420	> 25 < 50	> 50 < 100

### Interior + exterior ceiling panel without fire resistance requirement

For details see Chapter 8.1

BOARD THICKNESS (mm)	a (mm)	b (mm)	c <sub>1</sub> (mm)	c <sub>2</sub> (mm)
8	< 200	< 420	> 25 < 50	> 50 < 100
10	< 250	< 500		
12, 14	< 300	< 625		

### Flooring constructions

For details see chapters 7.5 and 7.6

BOARD THICKNESS (mm)	a (mm)	b (mm)	c <sub>1</sub> (mm)	c <sub>2</sub> (mm)
CETRIS® boards th. 12 mm in floating floor systems	Upper layer predrilled, max. 300 mm		> 25 < 50	50
CETRIS® PD (PDB) 16,18, 20, 22, 24 mm	≤ 300	Pursuant to load tables max. 621 mm		
CETRIS® PD (PDB) 16,18, 20, 22, 24 mm	≤ 400			

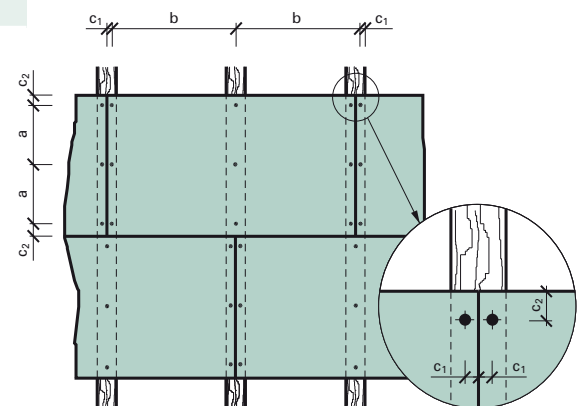
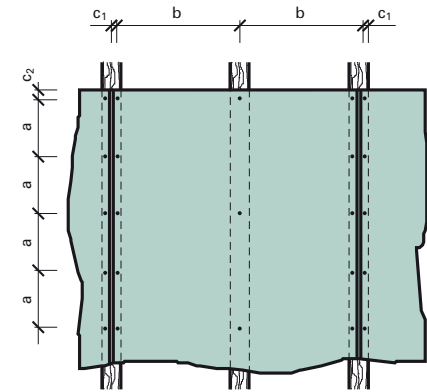

# Fastening of CETRIS® Cement Bonded Particleboard

## Fixation of CETRIS® cement bonded particleboards in exteriors

### Façade cladding with visible horizontal and vertical joints – VARIO system – for details see Chapter 8.3

CETRIS® boards are fixed in the VARIO system (visible joints) with stainless or galvanized screws with semi-circular or hexagonal heads and compressive water-tight washers. These washers are treated on the bottom side with vulcanized elastomer EPDM for water-tight and flexible material connection. The screw type also depends on the base type – the load-bearing grid applied.\*

For position stabilisation at least one fixed point (with the diameter of 5 mm) is needed. Dilations between boards 5 – 10 mm.

#### Types of screws/rivets

For details see Chapter 8.7.7. Auxiliary Materials.

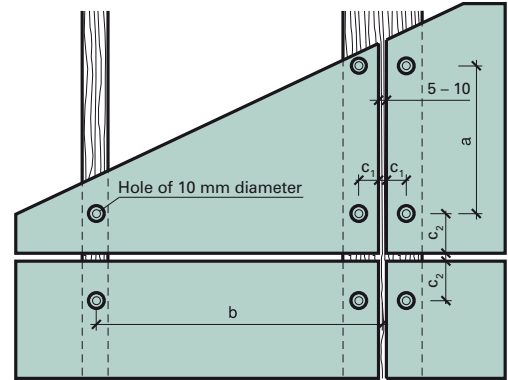
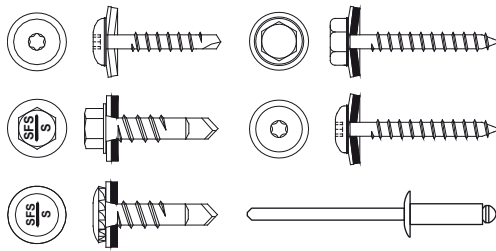

#### Board pre-drilling

CETRIS® boards must be pre-drilled:

- Diameter 8 mm for board lengths up to 1,600 mm
- Diameter 10 mm for board lengths over 1,600 mm (applies to screw/rivet diameter up to 5 mm)

BOARD THICKNESS (mm)	SCREW/RIVET SPACING a (mm)	SUPPORT SPAN b (mm)	SCREW DISTANCE FROM VERTICAL EDGE C <sub>1</sub> (mm)			SCREW DISTANCE FROM HORIZONTAL EDGE c <sub>2</sub> (mm)
			Timber	Zinc coat	Aluminium	
8	<400	<420	>25 <50	>30 <50 >50 <70*	>50 <70	>70 <100
10	<550	<500				
12	<500	<625				
14	<550	<625				
16	<550	<700				

\* Applies to lengthwise laying of CETRIS® boards (width >1,875 mm)

## Fixation of CETRIS® cement bonded particleboards in exteriors

### Façade cladding with overlapped joints – PLANK system – for details see Chapter 8.4

CETRIS® boards in the PLANK system (overlapped) are fixed with galvanized screws or stainless screws with sunken heads.

#### The board must be predrilled:

- outer – diameter of 8 mm
- inner – 1.2 times of the screw diameter

Recommended screws for CETRIS® board thickness 10 (12) mm, timber load-bearing grid:

- Screw 4.2 × 35 mm

Recommended screws for CETRIS® board thickness 10 (12) mm, EuroFox load-bearing grid:

- EJOT screw Climadur-Dabo TKR – 4.8 × 35 mm

#### Broad pre-drilling:

- 1.2 multiple of screw diameter (mostly 6 mm) – applies to screw diameter up to 5 mm
- Dilations between boards 5 – 10 mm.

**Note:** Recommended maximum length of CETRIS® board for PLANK system equals triple the span of the auxiliary vertical profiles (laths) – i.e. for board thickness 10 mm is max. 1,500 mm and for board thickness 12 mm is 1,875 mm.

#### Screw type:

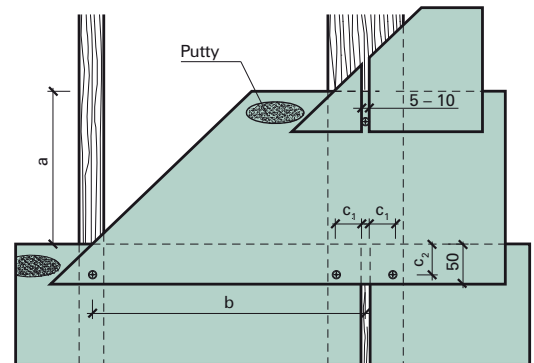

BOARD THICKNESS (mm)	SCREW/RIVET SPACING a (mm)	SUPPORT SPAN b (mm)	SCREW DISTANCE FROM VERTICAL EDGE C <sub>1</sub> (mm)			SCREW DISTANCE FROM HORIZONTAL EDGE c <sub>2</sub> (mm)	MAXIMUM LENGTH OF BOARD (mm)
			Timber	Zinc coat	Aluminium		
8	<400	<420	>35 <50		40		
10	<450	<500					
12	<350	<625					
14	<500	<625					
16	<500	<700					





When applying surface finishes to CETRIS® cement bonded particleboard the following principles must be observed:

- All applied materials must be stable in an alkali environment
- Before application of paints, glues or plasters on CETRIS® boards the boards must be covered with a primer for absorptive surface
- The materials must be applied to a dry board surface in compliance with the technological procedures required by the material manufacturers
- It is not recommended to apply hard materials but rather permanently elastic materials
- Dilation joints between boards may be covered with laths or filled with elastic filler (acrylic, polyurethane)
- Coating and sealing can be done after acclimatization of boards in installed condition

## 6.1 Joint filling with permanently elastic filler

When using CETRIS® boards for wall, partition and ceiling cladding, the boards must be dilated – visible joints must be left with the minimum width of 5 mm. The joints may be covered with laths, an inserted wooden, plastic or sheet metal profile, or filled with permanently elastic filler. The recommended fillers are the ones based on acrylic resins or polyurethanes. Silicon fillers may be applied to compact materials with acid pH, which is not the case of CETRIS® board. Where silicon filler must be used the contact surfaces must be treated with a primer.

The main principle for correct function of the dilation joints is elimination of three-sided adhesion in the joint, which causes uneven stress on the elastic filling and subsequently its tearing off the joint sides. This may be prevented by insertion of a slide insert – a polyethylene tape or string. The result is adhesion of the elastic matter on the opposite sides (edges of CETRIS® boards) only and even stress on the fill – the “chewing gum effect”.

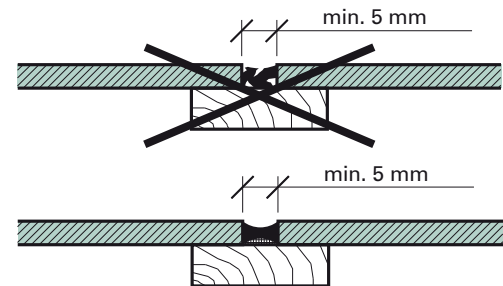

### Fillers recommended for joint filling

DESCRIPTION	PROPERTIES	APPLICATION	PROCEDURE	MANUFACTURER
<b>Acrylic elastic filler S-T 5</b> Single-component sealing joint filler creating permanent firm elastic joint.	High adhesion, coverable with acrylic and dispersion paints. After hardening resistant to weather effects including UV radiation. Maximum permitted deformation 20 %.	Filling joints in peripheral coats of cement bonded particleboards CETRIS® with joint widths 5 – 40 mm.	The surface must be clean, dry, firm, without grease and oil. It is recommended to treat the base with a primer – diluted filler S-T 5 (diluted in water in the ratio 1:3).	DEN BRAVEN
<b>Soudaflex 14 LM</b> Single-component elastic low-module filler on polyurethane basis.	Permanently elastic after maturation, maximum permitted deformation 25 %. When covered with regular oxidation paints the paint drying process may be delayed.	Joint filling with high contact movement. Joint width 5 – 30 mm.	The surface must be clean, dry, firm, without grease and oil. It is recommended to treat the base with a primer – Primer 100.	SOUDAL
<b>MAPEFLEX AC4</b> Single-component joint filling materials on acrylic resin basis.	Water- and air-tight permanently elastic joint filler.	Joint fill with maximum movement possible 15 – 20 %. Joint width 5 – 30 mm.	The surface must be clean, dry, firm, without grease and oil.	MAPEI
<b>BOTACT A4</b> Single-component acrylic filler.	Weather resistant, high ductility, can be covered with paint.	For joint sealing and construction board connection.	The surface must be clean, firm, without dust, grease and oil.	BOTAMENT
<b>SCHÖNOX S 20</b> Permanently elastic single-component joint filler on MS polymer basis.	High adhesion, resistant to water, weather and UV radiation, coverable with acrylic and dispersion paints. Maximum permitted deformation 25 %.	Filling joints in peripheral coats, balconies, dilation joints between construction slabs and in ceramic paving. For joint widths 5 – 20 mm.	The surface must be firm, dry, without dust, grease and other impurities. It is recommended to treat the base with a primer – Casco Primer 12.	SCHÖNOX

DESCRIPTION	PROPERTIES	APPLICATION	PROCEDURE	MANUFACTURER
<b>Henkel – Building acrylic</b> Dispersion sealing filler.	Does not contain solvents, coverable with paint, odourless, resistant to UV radiation.	Joint closing, joint width 5 – 30 mm.	The surface must be clean, dry, firm, without dust, grease and oil. It is recommended to moisten the base before application.	HENKEL
<b>Dexaflamm – R</b> Single-component elastic filler. FIRE PROTECTION APPLICATION.	After maturing permanently elastic, maximum permitted deformation 15 %.	Joint filling between boards, fire resistance. Joint width 5 – 20 mm.	The surface must be clean, dry, firm, without grease and oil. It is recommended to treat the surface with a primer – diluted filler Dexaflamm – R.	TORA
<b>Den Braven Pyrocryl</b> Single-component sealing filler on acrylic dispersion basis. FIRE PROTECTION APPLICATION.	High adhesion, deformation 12.5 %, retards flame (foams at temperatures above 200° C) coverable with paint after hardening.	Joint filling between interior boards. Joint width 4 – 25 mm.	The surface must be clean, firm, without dust, grease and oil.	DEN BRAVEN
<b>SIKA Firesil</b> Permanently elastic 1-component sealing filler on silicon basis. FIRE PROTECTION APPLICATION.	High adhesion, fire and water resistant.	Joint filling between boards, maximum joint width 15 mm.	The surface must be clean, firm, without dust, grease and oil.	SIKA
<b>SIKAFLEX 11 FC</b> Permanently elastic single-component joint filler on polyurethane basis.	High adhesion, water, weather and UV radiation resistant, coverable with paint, bridges deformations 15 %.	Filling joints in peripheral coats, balconies, ceramic paving, dilation joints.	The surface must be clean, firm, without dust and grease. For increased adhesion priming with primer Sika Primer 3N is recommended.	SIKA

## 6.2 Paints

Painting a CETRIS® board is the simplest surface finish. When applying surface finishes to CETRIS® cement bonded particleboards the following principles must be observed:

- CETRIS® board must be primed (for surface stabilisation, reduction of absorption, base unification)
- Top coat colours recommended by their manufacturers for a cement base must be used
- The product composition must be unified and the prescribed technological procedure must be followed (application method, technological breaks)
- The paints must contain pigments stable in an alkali environment. Unstable pigments may lead to discoloration.
- CETRIS® board surfaces must be dry, clean, without grease and oils
- Lime paints are not recommended
- In the case of visible CETRIS® board joints, the board edge must be treated with the same paint system.

For an even surface finish, the reverse side must also be provided with a protective primer.

For aesthetic reasons, CETRIS® boards with chamfered edges may be used.

If the customer wishes invisible joints under the surface finish, see Chapters 6.3, 6.4.

**Note:** In the case of old paint renewals on CBPB CETRIS® it is necessary to consider the existing paint condition and the type of the paint used (composition). The surface needs to be roughened and cleaned before application and the covering colour should be of the same composition as the original paint.

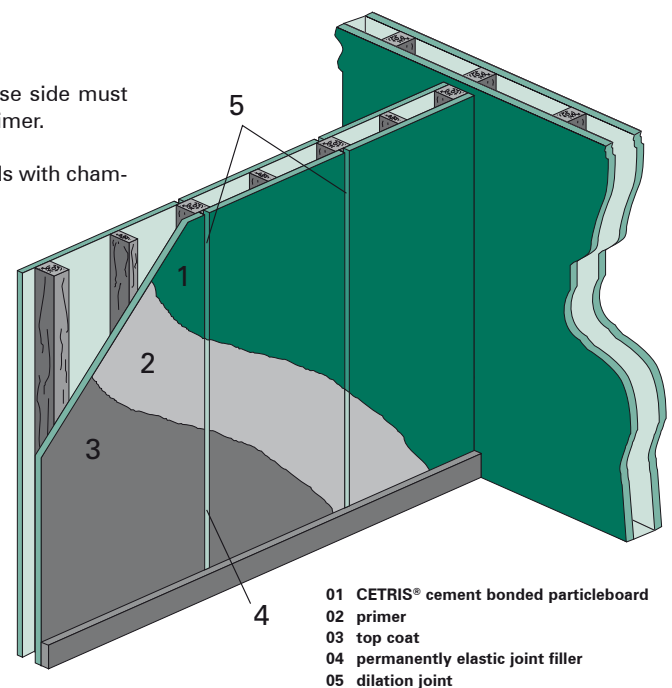

- 01 CETRIS® cement bonded particleboard
- 02 primer
- 03 top coat
- 04 permanently elastic joint filler
- 05 dilation joint

## Surface Finishes of CETRIS® Cement Bonded Particleboard

### Recommended paints for colour surface finish of CETRIS® boards

PRIMER	TOP COAT	MANUFACTURER
<b>FORTE Penetral</b> Molecular primer.	<b>ETERNAL</b> Universal dispersion paint.	AUSTIS
<b>ACRYL EMULZE</b> Water soluble primer.	<b>ACRYL COLOR</b> Water soluble acrylic top coat.	JUB
<b>HC-4</b> Water soluble primer.	<b>GAMADEKOR (F, FS, FS1, SIL, SA)</b> Water soluble top coats.	STOMIX
<b>EkoPEN</b> Deep penetrating agent.	<b>EkoFAS (EkoFAS Extra)</b> Smooth acrylic façade paint.	EKOLAK
<b>Quarzgrund</b> Resin-based filled primer.	<b>TEX Egalisationsfarbe</b> Water resistant highly permeable façade paint.	TEX COLOR
<b>Sto Prim Concentrat</b> Primer concentrate.	<b>Sto Color Royal</b> Matt acrylic based façade paint.	STO
<b>Mistral Primer</b>	<b>Mistral Univerzal</b> Water soluble enamel paint.	MISTRAL
<b>FANO</b> Façade penetration.	<b>RENOFAS J</b> Fine façade paint.	CHEMOLAK
<b>KEIM Silangrund</b> Hydrophobic primer on silan basis.	<b>KEIM Granital</b> Homogenised silicate based paint.	KEIM FARBEN
<b>BILEP P</b> Dispersion acrylic penetration	<b>ETERFIX BI</b> Dispersion acrylic matt top coat.	BIOPOL PAINTS
<b>Funcosil Hydro-Tiefengrund</b> Water soluble deep penetration.	<b>Funcosil Betonacryl</b> Anti-carbon acrylic paint for concrete.	REMMERS
<b>PEN-FIX</b> Water soluble off-white penetration.	<b>ELASTACRYL SATIN</b> Water soluble matt façade paint.	TOLLENS
<b>REMCOLOR Impregnation</b> Primer.	<b>REMCOLOR Roof paint</b> Water soluble dispersion paint for external use.	deREM
<b>Ceresit CT 17</b> Deep primer without solvents.	<b>Ceresit CT 44</b> Acrylate paint.	HENKEL
<b>Baumit universal primer</b> Primer for surface absorption levelling.	<b>Baumit Nanopor paint</b> Highly resistant vapour resistant paint on silicate basis for exteriors, dirt resistant.	BAUMIT
<b>Penad (H, BC-650)</b> Primer concentrate.	<b>Actin (F, SDF, DF, THERMO, H, I, L)</b> Water soluble surface finish.	POLYTEX

### Recommended paints for transparent surface finish of CETRIS® boards

PAINT	MANUFACTURER
<b>IMESTA IN 290</b> Preparation resistant to water on silicon oil basis.	IMESTA
<b>TOLLENS Hydrofuge Incolore</b> Hydrophobic solution for stone, masonry, concrete and plaster protection.	TOLLENS
<b>SIKAGARD 700S</b> Hydrophobic single-component solution on siloxan resin basis.	SIKA
<b>Herbol-Fassaden-Imprägnierung Hydrophob</b> Colorless, solvent impregnation agent for water resistant paints over all mineral bases.	Herbol Akzo Nobel Deco
<b>ACTIN LI</b> Water soluble clear varnish for inner walls.	POLYTEX

## 6.3 Interior Plasters

Plastering is surface finish hiding joints. CETRIS® boards must first be treated with a primer, the joints must be filled with permanently elastic filler, and then filling compound is to be applied across the surface in which bandage fabric with glass fibre is pressed. After application of the levelling layer again consisting of filling compound the final top coat is applied. It is recommended to always use a unified system by a single manufacturer of surface finishes and observe the technological procedures of the respective manufacturer throughout the application.

The reverse side of the CETRIS® board must be treated with at least one layer of paint (for example – primer or paint with a higher diffusion resistance) for prevention of board bending after application of the surface finish on the board face.

- 01 CETRIS® cement bonded particleboard
- 02 primer
- 03 filling compound
- 04 bandage fabric
- 05 plaster
- 06 dilation joint
- 07 permanently elastic gap filler

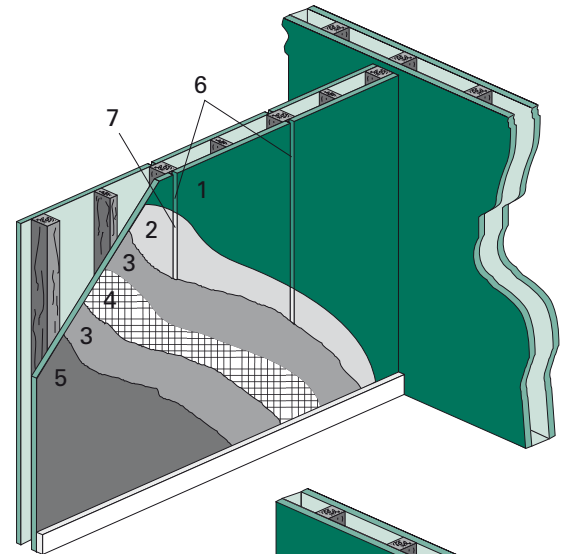

## 6.4 Exterior Plasters

Plastering is surface finish hiding joints. CETRIS® boards expand and shrink as a result of humidity dilation movements. To prevent damage of the façade plaster by hair-thin cracks caused by these movements, it is necessary to cover the CETRIS® board with an insulation board (polystyrene, mineral wool) with the minimum thickness of 30 mm. Mechanical anchoring may be needed in some cases. When using CETRIS® cement bonded particleboard 1,250 by 1,250 mm, the sufficient thickness of the insulation board is 20 mm. The insulation will create a separation layer to which other layers are applied, like in the case of the contact thermal insulating systems – spackle, bandage, noble plaster.

particleboards. Then the spackle is to be applied across the surface in which bandage fabric with glass fibre is pressed. After application of the levelling layer, again consisting of spackle, the final top coat is applied.

Mechanical anchoring of insulation boards to CETRIS® boards is implemented with disc dowels (self-cutting screw with disc head of high-quality polyethylene). The numbers of anchoring elements are specified by the manufacturers of the insulation boards, or the manufacturer of the discs. The minimum number is 4 pieces/m<sup>2</sup>.

### Recommended products:

EJOT SBH-T 65/25, screw diameter 4.8 mm, anchoring length 20 – 40 mm. Used in combination with self-cutting screws EJOT® Climadur-Dabo SW 8 R.

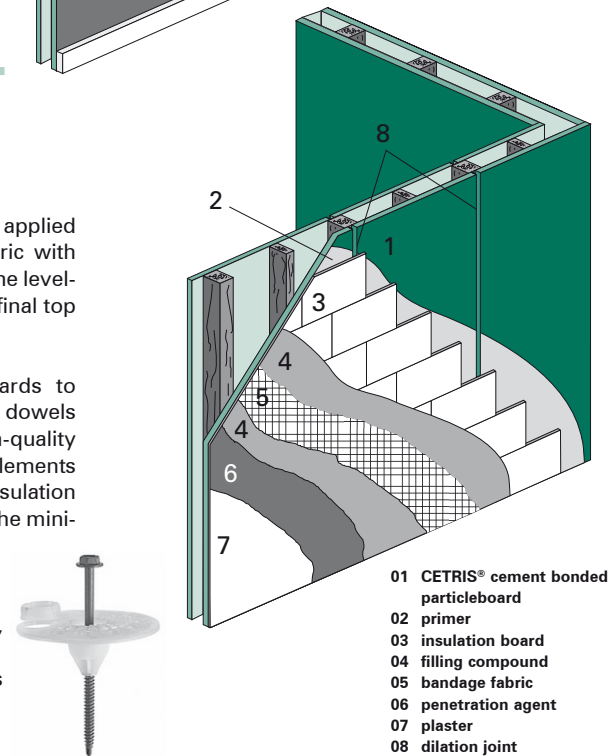

The CETRIS® boards must be treated with a penetration agent. Joint filling is not necessary in these cases. Polystyrene and mineral wool are glued with cement glue or low-expansion foam to cover the joints between the CETRIS® cement bonded

## 6.5 Wallpapers

In interiors, a surface finish with invisible joints may also be created by putting up vinyl wallpaper or glass fibre wallpaper. Paper wallpaper cannot be used. In these cases the CETRIS® cement bonded particleboards are primed, the joints are filled with permanently elastic filler and the wallpaper is glued with wallpaper glue. Further paints may be applied over glass fibre wallpaper. Vinyl wallpaper is designed for a surface finish with high aesthetic demand, washability and abrasion resistance.

When gluing vinyl wallpaper and wallpaper with glass fibre it is necessary to accurately follow the technological procedures recommended by the respective manufacturers.

- 01 CETRIS® cement bonded particleboard
- 02 primer
- 03 wallpaper glue
- 04 wallpaper
- 05 joint filler – permanently elastic
- 06 dilation joint

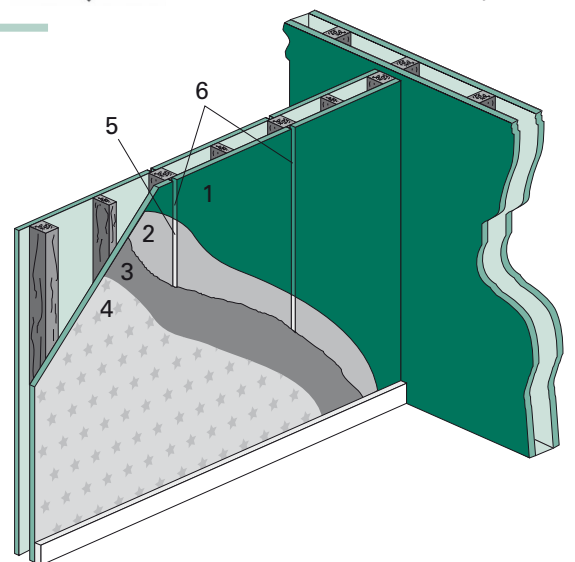

## 6.6 Ceramic Tiles for Interiors

When tiling, it is recommended to use permanently elastic fillers for joint filling between CETRIS® cement bonded particleboards, as well as for the tiling itself. The gluing filler must be spread across the whole surface not only in points. It is recommended either to place the dilation joints between the boards under the ones between tiles, or glue the tile just to one of the boards under it and leave it without glue in the part covering the joint. This solution is designed for spaces commonly exposed to water. Maximum tile size 200 by 200 mm.

- 01 CETRIS® cement bonded particleboard
- 02 penetration
- 03 gluing filler
- 04 ceramic tiles
- 05 joint filler
- 06 permanently elastic joint filler
- 07 dilation joint

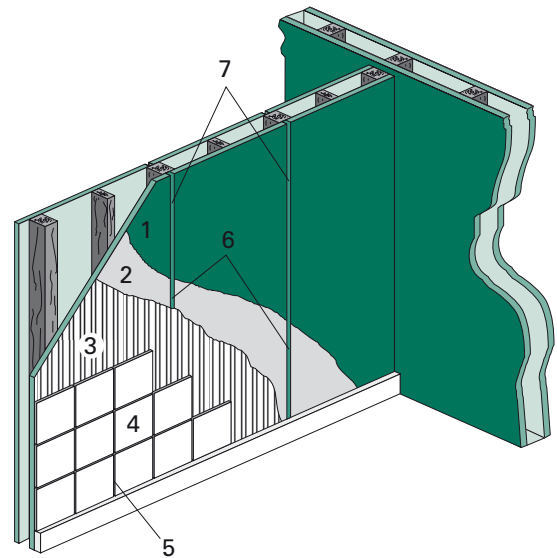

### Spaces with standard environment burden

SYSTEM COMPOSITION	MAPEI SYSTEM	SCHÖNOX SYSTEM	BOTAMENT SYSTEM	BASF SYSTEM	CERESIT SYSTEM	SIKA SYSTEM
Primer	Not required	Schönox KH	Botact D 11	PCI-Gisogrund	Ceresit CT 17	Not required
Gluing filler	ULTRAMASTIC III	Schönox PFK (Schönox PFK plus)	Botact M 21	PCI-Nanolight	Ceresit CM 16 – lower load Ceresit CM 17 – higher load	Sika Ceram 203
Joint filler (dilation joint filling)	ULTRACOLOR (MAPESIL AC)	Schönox WD FLEX (Schönox ES)	Botact M 32 / Botact S5	PCI-Flexfug	Ceresit CE 40 (Ceresit CS 25)	Sik Fuga

In non-ventilated sanitary spaces, showers and spaces with increased humidity exposure, CETRIS® cement bonded particleboards must be treated with hydro insulating paint:

- 01 CETRIS® cement bonded particleboard
- 02 penetration
- 03 hydro insulating plaster
- 04 gluing filler
- 05 ceramic tiles
- 06 joint filler
- 07 permanently elastic joint filler
- 08 dilation joint

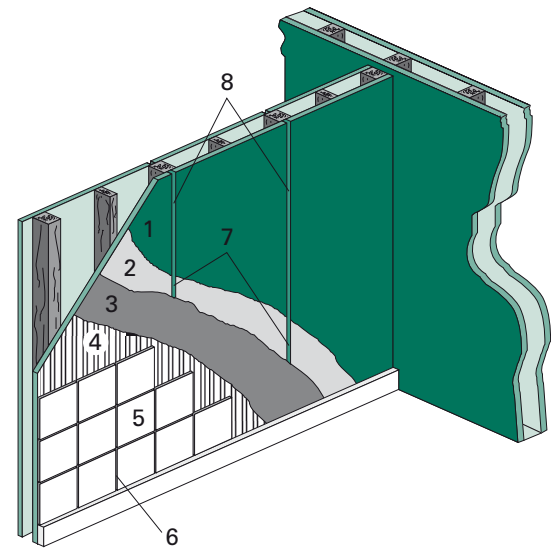

### Spaces with excessive exposure to moisture

SYSTEM COMPOSITION	MAPEI SYSTEM	SCHÖNOX SYSTEM	BOTAMENT SYSTEM	BASF SYSTEM	CERESIT SYSTEM	SIKA SYSTEM
Primer	Not required	Schönox KH	Botact D 11	PCI-Gisogrund	Ceresit CT 17	Not required
Hydro insulation (bandage of corners, dilations)	KERALASTIC (th. 1 mm) (MAPEBAND)	Schönox HA (Schönox Fugendichtband + bandage, coins)	Botact DF 9/ AB 78 - bande	PCI-Lastogum PCI-Dichtband Objekt	Ceresit CL 51 (Ceresit CL 52)	Sika Top 109 Elastocem, Sika Tape Seal S
Gluing filler	KERALASTIC	Schönox PFK plus	Botact M 21	PCI-Nanolight	Ceresit CM 16 – lower load Ceresit CM 17 – higher load	Sika Ceram 203
Joint filler (dilation joint filling)	ULTRACOLOR (MAPESIL AC)	Schönox WD FLEX (Schönox SU)	Botact M 32 / Botact S 5	PCI-Flexfug	Ceresit CE 40 (Ceresit CS 25)	Sika Fuga